



Blanchard Machinery Inc. 1890  
N.E. 150 Street  
North Miami Fla. 33181  
bmisalz@aol.com  
www.blanchardmachinery.net



*Highest Quality Post Drivers and Post Pullers*

# Multi-Pro™

*Gas Powered Driver*



MODEL: 301002

OWNERS MANUAL



EFFECTIVE SERIAL NO. 5002050

Form No. 301801.2.16



## TAKE SAFETY SERIOUSLY

Your safety, and the safety of others, is very important. The proper and safe use of your Rhino® post driver is an important responsibility and should be taken seriously. This owner's manual contains important safety information. Please read it carefully. The information and specifications included in this publication were in effect at the time of approval for printing. Rhino Tool Company, Inc. reserves the right, however, to discontinue or change specifications or design at any time without notice and without incurring any obligation whatever. No part of this publication may be reproduced without written permission from Rhino Tool Company, Inc.

To help you make informed decisions about safety, you will find important safety information in a variety of forms, including:

- Safety Labels on the post driver
- Safety Headings such as IMPORTANT SAFETY INFORMATION.
- Safety Section such as POST DRIVER SAFETY.
- Instructions how to use this post driver correctly and safely.
- Safety Messages Preceded by a safety alert symbol and one of three signal words, DANGER, WARNING, or CAUTION.

This owner's manual is considered a permanent part of the post driver and should remain with the post driver if resold, rented or loaned.

These signal words mean:



**Immediate hazards that will result in severe personal injury or death.**



**Hazards or unsafe practices that could result in personal injury.**



**Hazards or unsafe practices that could result in injury, product or property damage.**

# CONTENTS

Section	Page
<b>Safety Symbol Description</b> .....	i
<b>Table of Contents</b> .....	1
<b>Introduction</b> .....	2
<b>Post Driver Safety</b> .....	3
<b>Rhino® Multi-Pro™ Operating Instructions</b> .....	6
Starting the Engine .....	6
Hot Restart .....	7
Driving a Post .....	8
Installing a Chuck Adapter .....	9
Installing an Alternative Chuck .....	9
Multi-Pro™ Maintenance .....	10
<b>Rhino® Multi-Pro™ Service Instructions</b> .....	11
Servicing Crankshaft and Piston .....	12
Service of the Hammer and Anvil .....	13
Regular Service Period .....	18
<b>Rhino® Multi-Pro™ Parts &amp; Accessories List</b> .....	20
<b>Limited Warranty and Registration</b> .....	28
<b>Troubleshooting</b> .....	29

# INTRODUCTION

Congratulations on your selection of the Rhino® Multi-Pro™ post driver. We are certain that you will be pleased with your purchase. This post driver was built with the Honda GX35 engine. Honda supplies its own owner's manual that covers all the operator and service procedures associated with the Honda engine. Please read this manual as closely as you do the Rhino manual. The success that you experience with this tool is dependent upon your knowledge and understanding of how to properly operate and care for the Honda engine installed on your new post driver.

As you read this manual, you will find information preceded by a NOTICE symbol. That information is intended to help you avoid damage to your post driver, other property, or the environment.

We suggest you read the warranty information fully and understand its coverage and your responsibilities of ownership. Fill out the warranty registration card or online registration to receive Rhino® Limited Lifetime Impact Warranty. (See Page 28) Please read and understand the Honda warranty policy. The Honda warranty is separate from the Rhino® warranty and is subject to its own coverage conditions and responsibility requirements. The warranty is a separate document and is included with the Honda owner's manual.

When your Rhino® post driver needs scheduled maintenance, the technical service staff here at Rhino Tool Company is standing by

to assist you.. Our fully trained staff can ensure that you receive the correct service kit or direct you to the nearest Rhino Servicing Dealer.

The engine requires scheduled maintenance, keep in mind that your Honda service dealer is fully equipped and specially trained in servicing the Honda engine. Your Honda servicing dealer is dedicated to your satisfaction, and will be pleased to answer your questions and concerns.

Kindest Regards,  
The Rhino Tool Company Team



*Driven To  
Perfection!*

# POST DRIVER SAFETY

The Rhino® Multi-Pro™ gas powered driver is designed to drive fence post, ground rod, delineator post, vineyard post, form pin, tent stake and other like items into the ground.

## CAUTION

Uses, other than those intended, can result in injury to the operator as well as those around the operator. Damage to the driver and to the surrounding area may result as well. This post driver is intended for use by professional installers. Never allow children to operate this tool.

Most accidents can be prevented if you follow all instructions in this manual and on the post driver. The most common hazards are discussed below, along with the best method to protect yourself and others.

## WARNING

**UNDERGROUND UTILITIES:** Driving a post into an underground utility can be **EXTREMELY DANGEROUS**, exposing the operator and those around to potentially life threatening danger. Damage to surrounding property can also occur as a

result of a post being driven into an underground utility. Be absolutely certain that you are aware of all underground utilities in the area in which you intend to drive posts. Ensure that a certified locating service has identified all underground utilities prior to beginning your project. Failure to do so can be catastrophic. Underground utilities include but are not limited to: Electric, Gas, Telephone, Water, Sewer, TV Cable, Lawn Sprinklers, etc.

## WARNING

**GASOLINE:** Gasoline is **HIGHLY FLAMMABLE** and **EXPLOSIVE**. You can be burned or seriously injured when handling fuel.

## WARNING

**EXHAUST:** The exhaust from the engine contains poisonous carbon monoxide gas that can build up to dangerous levels in closed areas. Breathing carbon monoxide can cause unconsciousness or death. Never run the engine in a closed or even partly closed area where people may be present.

## WARNING

The engine exhaust

# IMPORTANT SAFETY INFORMATION

from this product contains chemicals known to the State of California to cause cancer, birth defects or other reproductive harm.

## WARNING

### ENGINE MAINTENANCE:

Improperly maintaining the engine on this power tool, or failure to correct a problem before operation, can cause a malfunction in which you can be seriously hurt or killed. In accordance with the engine owner's manual, always perform a pre-operation inspection of the engine before each use and correct any problem.

## WARNING

### DRIVER MAINTENANCE:

Improperly maintaining the driving mechanism on this power tool, or failure to correct a problem before operation, can cause a malfunction in which you can be seriously hurt or killed.

In accordance with this manual, always perform a pre-operation inspection of the driving mechanism before each use and correct any problem.

## POST DRIVER SAFETY... continued

**⚠ WARNING** Do not lend or rent your post driver without the instruction manuals. Be sure that anyone using it understands the information contained in these manuals.

**⚠ WARNING** Do not use this post driver for any purpose other than driving posts into the ground. Misuse may result in personal injury or property damage, including damage to the machine

**⚠ WARNING** Minors should never be allowed to use this power tool. Bystanders, especially children, and animals should not be allowed in the area where it is in use.

**⚠ WARNING** NEVER let your power tool run unattended. When it is not in use, shut it off and make sure that unauthorized persons do not use it.

**⚠ WARNING** Do not operate this post driver unless the operator is wearing safety glasses, safety shoes, hearing protection, gloves or any

## IMPORTANT SAFETY INFORMATION

other safety equipment advised by, ANSI, NIOSH, OSHA, or any other safety regulatory agency, the employer or the owner of this post driver.

**Hearing protection is required** as the post driver emits noise at 100 dB level. Bystanders should, at a minimum, wear safety glasses and hearing protection while in the presence of this power tool during operation. If not wearing protective gear, bystanders should keep a distance of 20 feet (6 m) from the post driver while in operation.

**⚠ WARNING** Prolonged use of a power tool (or other machines) exposing the operator to vibrations may produce white finger disease (Raynaud's phenomenon) or carpal tunnel syndrome. These conditions reduce the hand's ability to feel and regulate temperature, produce numbness and burning sensations and may cause nerve and circulation damage and tissue necrosis.

Not all factors contributing to white finger disease are known, but cold weather,

smoking and diseases or physical conditions that affect blood vessels and blood transport, as well as high vibration levels and long periods of exposure to vibration are mentioned as factors in the development of white finger disease.

In order to reduce the risk of white finger disease and carpal tunnel syndrome, please note the following:

- The Multi-Pro™ has been designed with Rhino® CIS™ anti-vibration handles to reduce the transmission of vibrations created by the machine to the operator's hands. An anti-vibration system is recommended for those persons using power tools on a regular or sustained basis.
- The handle opposite the throttle handle has been fitted with an EPDM foam grip further dampening vibrations.
- Wear gloves and keep your hands warm.
- Ensure that the EPDM foam and the spring dampening system are in good working condition.

## POST DRIVER SAFETY... continued

- Ensure the post driver has no loose components. Loose components lead to high vibration levels.
- Maintain a firm grip at all times, but do not squeeze the handles with constant, excessive pressure. Take frequent breaks.

All of the above mentioned precautions do not guarantee that you will not sustain white finger disease or carpal tunnel syndrome. Therefore, continual and regular users should closely monitor the condition of their hands and fingers. If any of the above symptoms appear, seek medical advice immediately.



**WARNING** DO NOT modify this power tool in any way.



**CAUTION** DO NOT put anything other than a post into the chuck on the driver.



**CAUTION** DO NOT operate your post driver unless it is on a post to be driven. Operation of the driver without it driving on a post could

damage the power tool.



**CAUTION SURROUNDINGS:** This power tool emits noise at 100 Db, which may be disturbing to animals and livestock. Ensure prior to operation, that any livestock are cleared from the operational area to prevent a situation in which startled livestock become a safety hazard.

### WARNING LABELS

If your post driver's warning label is marred or destroyed, replace it immediately. Simply call Rhino Tool Company and we will send you a new warning label at no expense to you.

### End of Life Cycle

When your Rhino® gas powered driver is coming to the end of its life cycle, destruction of the unit should be conducted according to international and local environmental regulations.

The gas powered post driver contains:

- Fuel

## IMPORTANT SAFETY INFORMATION

- Oil
- Rhino® Pro Series Lubricant
- Electric components
- Plastic-steel and aluminum components.

### Rhino® Multi-Pro™

#### Specifications

imperial (metric)

Overall Dimensions	10.75 x 17 x 26 in. (273 x 432 x 660 mm)
Weight	44 lb (19.9 kg)
Engine Configuration	4-stroke, 35.8 cc
Performance	1720 bpm
Fuel	Unleaded Gas, US 86 Octane (>Euro 91)
Fuel Capacity	0.67 US qt. (0.63 ltr)
Engine Oil	SAE 10W-30
Lubricant	Rhino® Pro Series Lubricant
Noise	≤ 100 Db
Vibration	TBC

# Multi-Pro™ Operating Instructions

Your Rhino® Multi-Pro™ Gas Powered Post Driver is an efficient and effective power tool designed and developed to tackle a difficult and time consuming task, driving posts.

It is very important to understand that your post driver is a very powerful machine. With proper care and maintenance, your Rhino® Multi-Pro™ will give you many

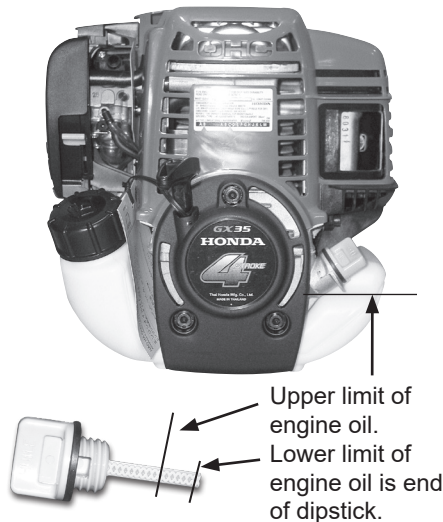

Fig. 1  
6

years of trouble free service.

You must read and understand your post driver operating instructions before using the post driver. It is also very important that you make sure all operators are trained to operate your post driver safely. If you or any operator doesn't understand any of the instructions in this manual, call Rhino Tool Company at 866-707-1808 or 309-853-5555 and we will assist you with any questions you may have.

**WARNING** AVOID SERIOUS INJURY OR DEATH  
READ THIS MANUAL BEFORE USING YOUR POST DRIVER.

Visually inspect your Multi-Pro™ Post Driver before use. The interior of the chuck tube should be checked for obstructions, damage or wear to the chuck tube and anvil inside. The outer surfaces of the driver should also be inspected for any defects. Do not use the Multi-Pro™ if there is any damage or wear until the damage or wear is corrected and repaired.

Check all fluid levels, i.e. engine oil and fuel and fill as needed as per manufacturer's specifications. (Fig. 1)

**NOTE** Proper oil level is essential to the operation of the post driver. Overfilling of the oil will result in loss of power and may cause permanent damage to the engine.

**WARNING** USE ALL RECOMMENDED SAFETY EQUIPMENT.

Rest the driver on a solid surface, i.e. tailgate, bench, or debris free solid ground and posture your body in a safe position. DO NOT start the driver anywhere but an open, well-ventilated area. It is recommended that the Multi-Pro™ only be used outdoors and never inside an enclosed building.

## Starting the Engine:

To start a COLD engine, move the choke lever to the CLOSED position (Fig. 3). Lock the throttle into high idle position. (Fig. 2) This is done by depressing the



## Multi-Pro™ Operating Instructions... continued

trigger and the high idle lock simultaneously. The throttle is now in the high idle position.

To start a WARM engine, leave the choke lever in the OPEN position and do not lock the throttle into the high idle position. Press the priming bulb repeatedly (Fig. 4) until fuel can be seen in the clear-plastic

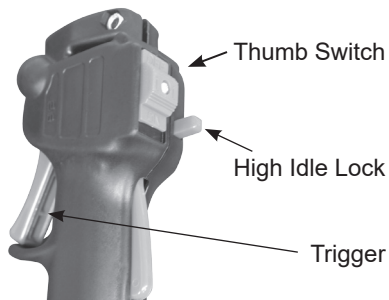

Fig. 2

Choke Closed

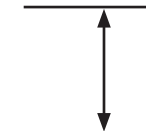
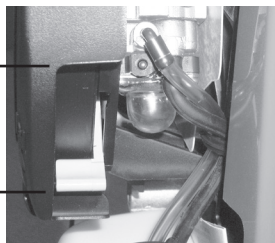

Fig. 3



fuel return tube.

Slide thumb switch on throttle handle down or into the ON position.

Grasp the starter grip lightly until you feel resistance, then pull briskly in the direction of the arrow as shown in Fig. 5. Return the starter grip gently.

**CAUTION** Do not extend the starter rope to its full length as it can cause damage the recoil mechanism.

**CAUTION** An operator should never wrap the starter rope around their hand. This will cause serious injury.

Priming Bulb

Fuel Return Line (clear plastic tube)

Fig. 4

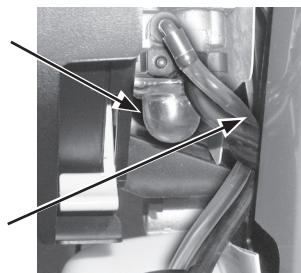

**NOTE** Do not allow the starter grip to snap back against the engine. Return it gently to prevent damage to the starter.

If the choke lever was moved to the CLOSED position to start the engine, gradually move it to the open position as the engine warms up. As the engine warms up also release the high idle lock by slightly depressing the trigger and then immediately releasing it. Use caution as to not engage the clutch. Dry-Firing will shorten the life of the post driver and could cause damage.

**Hot Restart** If the engine is operated at higher ambient temperatures, then turned

Starter Grip

Fig. 5

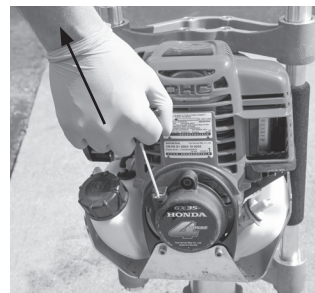

## Multi-Pro™ Operating Instructions... continued

off and allowed to sit for a short time, it may not restart on the first pull. If necessary, use the following procedure:



**WARNING**

**IMPORTANT  
SAFETY  
PRECAUTION**

Failure to follow instructions can result in personal injury

Turn the engine switch to the **OFF** position before performing the following procedure. This will prevent the engine from starting and running at maximum speed when the throttle is in the **MAX.** speed position. If the engine starts with the throttle in the **MAX.** speed position, the post driver will operate at maximum power. This may result in **personal injury** and damage to the post driver.

1. Turn the engine switch on the post driver to the **OFF** position.
2. Move the choke lever to the **OPEN** position.
3. Hold the throttle in the **MAX** speed position.

4. Pull the starter grip 3 to 5 times.

Follow the **STARTING THE ENGINE** procedure on the previous page and start the engine with the choke lever in the **OPEN** position.

### Driving a Post

Holding the post driver with your left hand on the foam grip and your right hand on the throttle will position the driver to direct the engine exhaust away from the operator (**Fig 6**). (See Exhaust Warning) Insert a post into the Multi-Pro™ making sure the end of the post to be driven is in the correct location on the ground. (**Fig. 7**) Position the driver aligned and centered to the post. If not aligned properly, damage

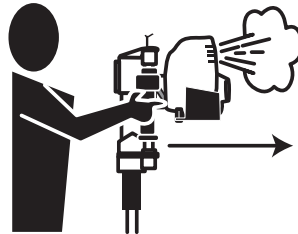

Fig. 6

could be caused to the driver or the post.

Apply steady downward pressure to the handles and apply enough throttle to engage the clutch and hammer.

Once you are confident that the post is driving straight, apply full throttle to the driver until the post is driven to the desired depth.

Release the trigger dropping the engine RPM back to idle before removing from the post. When the engine has returned to

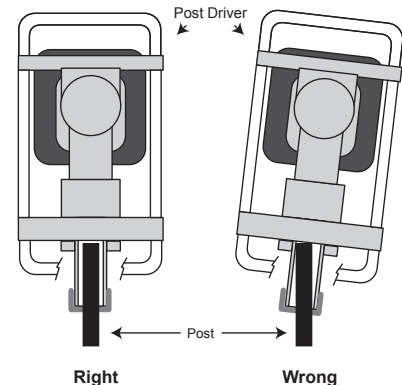

Fig. 7

## Multi-Pro™ Operating Instructions... continued

idle, proceed to the next post repeating the previous method of driving a post.

### Installing a Chuck Adapter



#### **CHUCK SIZE:**

A chuck or chuck adapter that is too large for the post being driven may damage the driver and may damage the end of the post. Using a the appropriate chuck or chuck with adapter will align the post to optimum striking position and

prevent damage to the driver. See the chart below to specify the appropriate adapter for your application. Chucks and chuck adapters wear out and should be replaced as needed. Inspect your driver's chuck and chuck adapters frequently.

The Multi-Pro™ is equipped with the Rhino® Chuck-Lok™ Adapter System. It is comprised of the master chuck, the locking nut and two-piece adapters.

Type or Size of Post to be Driven (mm)	Chuck/Accessory Required
Fiberglass T-Post	1¾" (44.45) Adapter
T-Post	1¾" (44.45) Adapter
5/8" (15.87) to 3/4" (19) Ground Rod	1" (25.4) Adapter
Tent Stake	Tent Stake Chuck
Concrete Form Pin	1" Adapter
1" (25.4) to 1-5/8" (41.27) Post	1¾" (44.45) Adapter
1-7/8" Post	2" (50.8) Adapter
2"(50.8) to 2-3/8" (60.32) Post	Master Chuck
1-1/2" (38.1) to 2-1/2" (63.5) Square Post and Square Post Sign Anchor	Short Chuck and Drive Cap
1.2 - 4 lb Channel Post and Channel Post Sign Anchor	Channel Chuck and Long Anvil

Note: Custom chucks may be available for your specific application contact Rhino Tool Company.



**WARNING**

**ALWAYS HAVE  
THE LOCKING**

**NUT IN PLACE WHEN DRIVING**

**POSTS:** The Chuck-Lok™ locking nut should always be tightened onto the master chuck to protect the chuck threads, even when not using an adapter. Failure to do so exposes the chuck to possible damage.

The two-piece adapter design is a solution for the occasional flared post. Should a post flare and lodge inside the chuck when using the adapter, in most cases the operator can loosen the locking nut letting it slide down the post, then lift the driver off the post. The operator can quickly re-insert the adapter, secure them with the locking nut and resume driving posts. See **Fig. 8** for steps for installing Chuck-Lok™ adapters.

### Installing an Alternative Chuck

The Multi-Pro™ quick change design allows the operator to quickly remove the standard master chuck and install an alternative chuck configuration for your post driving application.

## Multi-Pro™ Operating Instructions... continued

Turn off the engine and allow it to cool. Position the post driver on a work bench or level surface. Using a 1/4" hex bit socket wrench loosen and remove the 4 chuck bolts (p/n 300717-4) and lock washers (p/n 300750-4). Replace lock washers if they are worn. Remove the chuck and set it aside in a convenient place to store until needed.

Align the alternate chuck to the bolt holes on the lower body, taking into account the position of slots or internal configuration for the post to insert according to the operator side of the post driver. Insert bolts through the lock washers and into the bolt holes. Hand tighten bolts. **Using a torque wrench set to 132 lb/in (14.9 Nm) for**

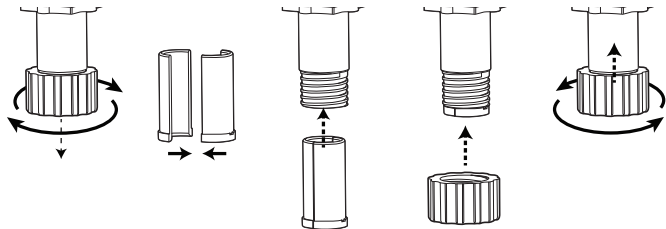

**Fig. 8 - Hand tighten ONLY. No Tools.**

**stainless bolts or 251 lb/in (28.4 Nm) for black oxide bolts**, tighten them in a crossing pattern to the correct torque.

If alternative anvil parts are needed please follow the instructions provided with alternative chuck kit.

If you do not see a chuck option for a specific post, contact your Rhino Tool Company representative to inquire if there is an option available.

### Maintenance of the Multi-Pro™

**⚠ WARNING NEVER REFUEL WITH THE ENGINE**

**HOT OR RUNNING:** Never refuel your Multi-Pro™ with the engine hot or running as there is a possibility the flammable fumes from the gasoline can ignite, causing severe injury and/or damage to you/your Multi-Pro™ and the surrounding area. Follow engine manufacturer's instructions for the refueling of the engine.

**⚠ WARNING DO NOT OPEN CRANKCASE COVER WHILE ENGINE IS RUNNING.**

With each use check the engine oil level, air filter, and all fasteners. If necessary, add oil, clean or replace the air filter and tighten any loose nuts, bolts, or any other fastener. (See page 6 for engine oil level)

Change engine oil as per engine manufacturer's specifications. Dispose of used oil in accordance with any local, state, or federal regulations.

To help insure years of operation, wipe down the Multi-Pro™ with a clean cloth after each days use.

**Refer to the Service Instructions for more detail regarding maintenance of the Post Driver.**

# Multi-Pro™ Service Instructions

Following the service requirements for the Multi-Pro™ will insure years of trouble free operation. Always refer to the Honda GX35 manual for maintenance and service on the engine. The following instructions are for the Rhino® Multi-Pro™ specifically with general instructions for the Honda GX35. Before any service is preformed, remove the spark plug wire from the spark plug and ground it to the engine body to prevent any accidental start-up of the engine.

## Each Use:

1. Check engine oil level. Use SAE 10W-30 to top oil level off, if necessary. Correct fill level shown on page 6.
2. Check condition of the engine air cleaner. The air cleaner can be cleaned or replaced. Consult your Honda engine manual for instructions.
3. Check crankcase lubrication by removing the Crankcase Cover. Instructions for service are on page 12.
4. Check all engine and post driver fasteners. Retighten to proper specifications if

necessary. (See Bolt Torque Specifications on page 27)

5. Check overall condition of post driver before use. Any loose, broken or worn parts should be replaced before using post driver.

## Every 10 hours or first month use of a new or rebuilt Multi-Pro™

1. Change engine oil following the requirement for the Honda GX35. Dispose of used oil according to all local, state, and federal regulations.
2. Check all engine and post driver fasteners. Retighten to proper specifications if necessary.
3. Check crankshaft and piston lubrication. (See page 12 for instructions.)

## Every 3 months or 25 hours of use

1. Change engine oil following the requirement for the Honda GX35. Dispose of used oil according to all local, state, and federal regulations.

2. Replace air cleaner elements. This should be performed more often if operated in dusty areas.
3. Check crankshaft and piston lubrication. (See page 12 for instructions.)
4. Check all engine and post driver fasteners. Retighten to proper torque specifications if necessary. (See page 27)

## Every 6 months or 50 hours of use

1. Change engine oil following the requirement for the Honda GX35. Dispose of used oil according to all local, state, and federal regulations.
2. Replace air cleaner elements. This should be performed more often if operated in dusty areas.
3. Check crankshaft and piston lubrication. (See page 12 for instructions.)
4. Check all engine and post driver fasteners. Retighten to proper torque specifications if necessary. (See page 27)

## Every 12 months or 100 hours of use

1. Change engine oil following the

## Multi-Pro™ Service Instructions... continued

requirement for the Honda GX35. Dispose of used oil according to all local, state, and federal regulations.

2. Replace air cleaner elements. This should be performed more often if operated in dusty areas.
3. Check crankshaft and piston lubrication. (See page 12 for instructions.)
4. Remove and service the hammer and anvil. (See page 13 for instructions.)
5. Check all engine and post driver fasteners. Retighten to proper torque specifications if necessary. (See page 27)

### Servicing Crankshaft and Piston Lubrication

(Fig. 9) The crankcase cover (p/n 300132) is designed for easy, “no tool” inspection and maintenance. To remove the cover, grip it tightly with your hand and twist it left (counter-clockwise.) Use caution not to lose or damage the O-ring Seal (p/n 301617).



**CAUTION** DO NOT OPEN CRANKCASE COVER WHILE ENGINE IS RUNNING



**CAUTION** DO NOT USE A HAMMER OR WRENCH TO LOOSEN THE COVER AS IT MAY CAUSE DAMAGE TO THE DRIVER.

Visually inspect the color and amount of Rhino® Pro Series Lubricant inside the crankcase. There should be a ring of Rhino® Pro Series Lubricant collected to the wall inside the crankcase. Should the depth of the ring from the wall inward



Fig. 9 - Crankcase Cover

measure 1/8" (3mm) or less (Fig. 10) this indicates the Rhino® Pro Series Lubricant is low. The maximum level should not be more than 1/4" (6mm). If the amount of Rhino® Pro Series Lubricant appears to be low, add a small amount of Rhino® Pro Series Lubricant. Use only Rhino approved Rhino® Pro Series Lubricant (p/n 300500.)



**CAUTION** DO NOT OVER-FILL RHINO® PRO SERIES LUBRICANT AS IT CAN DAMAGE THE DRIVER AND THE HONDA ENGINE.

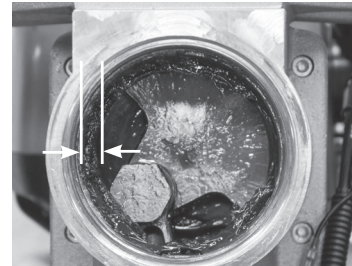

Fig. 10 - If ridge of Rhino® Pro Series Lubricant measures 1/8" or less, add a small amount. At maximum level it should measure 1/4".

## Multi-Pro™ Service Instructions... continued

If the Rhino® Pro Series Lubricant appears burnt or has an odor of burnt lubricant it should be removed and the post driver needs further maintenance. This is detailed in the section titled “Service of the Hammer and Anvil.”

In the event of complete removal of old Rhino® Pro Series Lubricant and adding fresh Rhino® Pro Series Lubricant (**Fig. 11**) rotate the crankshaft with connecting rod and crank pin until the crank pin is in the 12:00 position, then add Rhino® Pro Series Rhino Pro Series Lubricant

Rotate Crankshaft until crank pin is in 12:00 position.

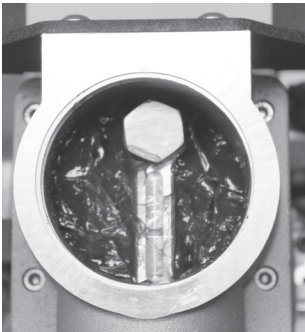

**Fig. 11** - After completely cleaning out old lubricant, add new Rhino® Pro Series Lubricant till level with the bottom edge of the crank pin head.

(p/n 300500). The level of Rhino® Pro Series Lubricant should be to the bottom of the crank pin. When the required service has been performed in the crankcase, inspect the o-ring seal and replace it on the crankcase cover. Position the crankcase cover on the Multi-Pro™ body carefully to start the threads and once in the thread groove, with your hand twist to the right (clock-wise) until it is securely in contact with the post driver body.

**⚠ CAUTION** **HAND TIGHTEN ONLY. DO NOT OVERTIGHTEN.** Do not use tools, such as a hammer or wrench, to tighten the crankcase cover as it will damage the driver.

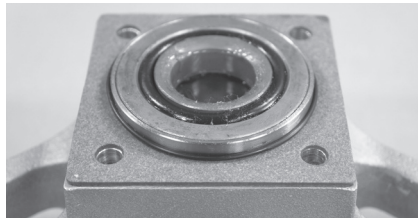

**Fig. 12** - View of the Lower Driver Body Assembly when removed from the post driver. 301115

## Service of the Hammer and Anvil

The tools required for servicing the hammer and anvil are, a 9/64" hex wrench, a 1/4" hex wrench, a 7/8" deep well socket with handle, a torque wrench that reads in inch/pounds, and Loctite primer and threadlocker.

Remove the crankcase cover (**see crankcase cover CAUTION on page 12**) and clean out any old Rhino® Pro Series Lubricant from inside the crankcase.

Remove the four (4) chuck bolts (p/n 300717-4) and disconnect the chuck. Remove the four (4) lower bolts (p/n 300701-4) from the lower driver body and the four (4) bolts (p/n 300715-4) from the upper handle bracket. Use caution as the handle tubes have four (4) anti-vibration springs (p/n 610010-4) installed and under tension. Grasping the upper handle bracket pull it directionally away from the driver body to create a separation between them. While separated, lift and remove the upper driver body assembly (p/n 301016) from the post driver assembly and set aside.

## Multi-Pro™ Service Instructions... continued

Observe the lower driver body, it should appear as shown in **Fig. 12**. The anvil o-ring retainer (p/n 301115) will sometimes be removed with the lower driver body or remain in place at the base of the cylinder of the upper driver body.

Remove the anvil o-ring cup (p/n 301095) and the anvil (p/n 301165). This can be accomplished by pushing a hammer handle into the chuck tube from the opposite side. When the parts are removed, note the order and disassemble for inspection. Check the anvil for damage. The anvil o-ring (p/n 301615) should be replaced at this time. Clean the anvil and carefully replace the anvil o-ring. (**Fig 13**) shows an anvil with



**Fig. 13** - Anvil with O-ring in place.  
14

the o-ring in place.

Inspect inside the sleeve in the lower body for damage. If the ledge that supports the anvil o-ring cup is damaged, replace with new sleeve (p/n 301038.)

Remove the large retainer o-ring seals (p/n 301614-2) and the large retainer (p/n 301105) from the anvil o-ring cup. Inspect the large retainer. The large retainer o-ring seals should be replaced at this time. Replace the large retainer if there are any signs of damage or excessive wear.

The anvil o-ring retainer (p/n 301115) can be removed from the end of the cylinder in the post driver body by hand. Use caution as it can become sharp with use of the

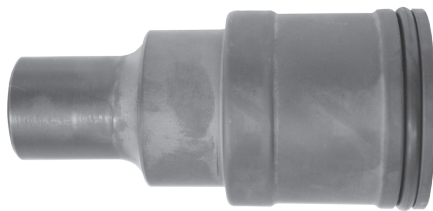

**Fig. 14** - Small end of Hammer is toward the anvil.

driver. Remove the hammer (p/n 301085), piston and connecting rod assembly (p/n 301075) by removing the crank pin (p/n 300050). Access to the crank pin is achieved by removing the crankcase cover (p/n 300132), which is described in the section titled “Servicing Crankshaft and Piston Lubrication.” Remove the crank pin using the 7/8" deep well socket.



**CAUTION** The crank pin has **LEFT-HAND**

**THREADS.** Use caution stabilizing the connecting rod and crankshaft (p/n 300040) to avoid damaging them. Use a small wood or plastic block to keep the crankshaft from rotating. When the crank pin is removed, the piston, connecting rod, and hammer can be removed by pushing the connecting rod down into the cylinder until it can be removed from the bottom of the post driver body. Note position of the hammer. The small end of the hammer is toward the anvil as shown in (**Fig. 14.**) Clean and inspect the hammer for damage. The hammer o-ring seal (p/n 301610-2) should be replaced at this time.



## Multi-Pro™ Service Instructions... continued

Clean and inspect the piston and connecting rod. Insert the crank pin into the bearing on the connecting rod. If there is excessive play between the two, the connecting rod and possibly the crank pin should be replaced. Check the movement in the bearing in the piston side. If there is excessive play the piston assembly should be replaced. The piston o-ring seal (p/n 301610-2) should be replaced at this time. (See **Fig. 15.**)

Clean and inspect the cylinder and crankcase for any damage or wear. Replace any damaged parts. Lubricate the cylinder, piston, and connecting rod with Rhino® Pro Series Lubricant (p/n 300500.) Insert the connecting rod, of piston assembly, into the cylinder. Push the

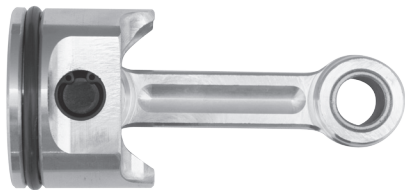

**Fig. 15** - Piston with Connecting Rod and O-ring Seal in place.

piston up the cylinder until the bearing in the connection rod aligns with the threaded hole for the crank pin. Apply Loctite Primer N 7649 to the threads in the crankshaft and crank pin. Let the Primer dry completely. Apply a line of Loctite 243 Threadlocker to the threads on the crankshaft. Insert the crank pin through the bearing and start the threads into the crankshaft by hand. Use caution holding the connecting rod and crankshaft (p/n 300040). The connecting rod and crankshaft can be damaged. Use a small wood or plastic block to keep the crankshaft from rotating.

**⚠ CAUTION** These are **LEFT-HAND THREADS.**

Tighten the crank pin using the 7/8" deep well socket. Torque to 360 inch/pounds (40.6 Nm). Add Rhino® Pro Series Lubricant (p/n 300500) to the crankcase to the level shown in **Fig. 11.** (See **Caution: Do not overfill Rhino Pro Series Lubricant on page 12**)

If Lubricant has been completely removed, add 2.75 oz or 81.32 ml of Rhino® Pro

Series Lubricant or until level with the bottom of the crankpin head. Close the crankcase by placing the crankcase cover o-ring seal onto the crankcase cover. Place the crankcase cover onto the post driver body, start the thread, and twist to the right (clockwise) with your hand until it is secure against the post driver body. (See **Caution: Do Not Overtighten on page 13**)

Lubricate the hammer with Rhino® Pro Series Rhino Pro Series Lubricant. Insert the hammer into the cylinder, taking note of the small end toward the anvil as shown in **Fig. 14.** Push the hammer into the cylinder making room to insert the anvil o-ring retainer. Apply Rhino® Pro Series Lubricant to the anvil o-ring retainer and place the small end into the cylinder. The Rhino® Pro Series Lubricant should hold it in place. Lubricate with Rhino® Pro Series Lubricant and assemble the large retainer and the two (2) large retainer o-ring seals in the order shown in (**Fig. 16 on next page**) and assemble into the anvil o-ring cup.

**⚠ CAUTION** THE LARGE RADIUS OF THE LARGE RETAINER MUST BE POSITIONED UPWARD FACING THE HAMMER OR IT WILL CAUSE DAMAGE TO THE DRIVER.

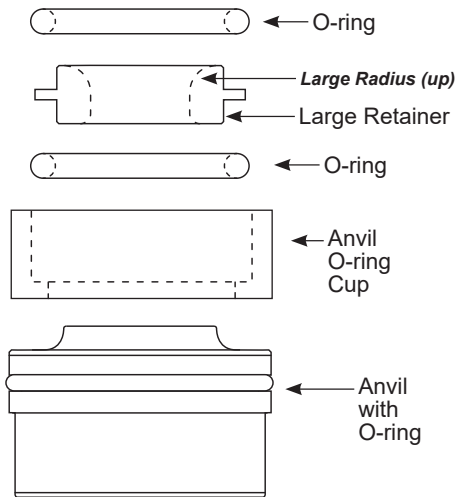

**Fig. 16** - Insert O-ring into Anvil O-ring Cup, then insert Large Retainer (with large radius up), then insert other O-ring.

Clean and inspect the lower driver body (p/n 301032) for any damage or excessive wear. Replace if necessary. Lubricate inside of the sleeve of the lower body with Rhino® Pro Series Lubricant. Lubricate the anvil with Rhino® Pro Series Lubricant. Insert the anvil with new anvil o-ring into lower body, making certain that the anvil is seated into the lower body. Insert the anvil o-ring cup into the lower body. Discard the used O-ring cup, O-ring (p/n 301618) and Gasket. Replace with new O-ring cup and Gasket. The O-ring is obsolete and no longer needed. The assembly should look like Fig. 12, but without the o-ring.

All threads on the bolts and in the body and lower body need to be clean and free of any dried threadlocker or debris. Apply Loctite Primer N 7649 to the external and internal threads. The primer must be dry before assembly. Apply the gasket to the lower body assembly by removing the paper backing and exposing the adhesive on one side. With the adhesive on one side. With the facing the lower body, press gasket into place making sure the bolt

holes are lined up. Apply threadlocker to the threaded holes on the body. The threadlocker needs to be applied starting at the bottom of the threaded hole and apply a bead of threadlocker up to the top of the thread. With the gasket in place on the lower body, remove the paper backing on the other side of the gasket. Grasp the Upper Handle Bracket and pull toward the Upper Handle, depressing the upper Springs. Seat the Lower Body onto the upper Body making sure the bolt holes are aligned. Gently let the upper handle bracket slide back into place. Place the lock washers onto the lower body bolts. The lock washers are a two (2) piece design. Do not separate the parts of the lock washer. Insert and start by hand the four (4) lower body bolts through the lower body and into the body. Use a 1/4" hex wrench to tighten the bolts in a crossing pattern. Check for any misalignment or binding when joining the parts. Do not use excessive force. Using a torque wrench set to 132 lb/in (14.9 Nm) for stainless bolts or 251 lb/in (28.4 Nm) for black

## Multi-Pro™ Service Instructions... continued

oxide bolts, tighten to the correct torque. Hand thread the four (4) upper handle bolts through the handle bracket and into the body. Do not use lock washers on the upper handle bolts. Use a 1/4" hex wrench to tighten the bolts in a crossing pattern. **Using a torque wrench set to 132 lb/in (14.9 Nm) for stainless bolts or 251 lb/in (28.4 Nm) for black oxide bolts, tighten to the correct torque.**

Apply Loctite Primer N 7649 to the threaded holes in the lower body and to the chuck bolts. Let the primer dry before assembly. Apply the threadlocker to the threaded holes in the lower body. The threadlocker needs to be applied starting at the bottom of the threaded holes and apply a bead of threadlocker up to the top of the thread. Insert the chuck bolts into the lock washers. The lock washers are two (2) piece design. Do not separate the parts of the lock washer. Insert and start the four (4) chuck bolts through the chuck and into the lower body. Use a 1/4" hex wrench to tighten the bolts in a crossing pattern. Use

a torque wrench set to 132 lb/in (14.9 Nm) for stainless bolts or 251 lb/in (28.4 Nm) for black oxide bolts tighten to the correct torque.

To clean and lubricate the anti-vibration handle springs loosen the two bolts located in the recesses of the top handle assembly (p/n 301222) until the upper handle and handle collars are free from the upper handle bracket. Slide the lower handle downward to expose the lower springs. Clean the springs, upper handle bracket cups, and upper and lower handle collars with acetone or cleaning solvent. Apply Rhino lubricant to springs, right and left collars of the lower handle, top cups of the upper handle bracket, and upper handle collars. Slide the lower handle assembly back up into position. Apply Loctite Primer N 7649 to the handle bolts and the threaded holes in the handles. Let the primer dry. The threadlocker needs to be applied starting at the bottom of the internal thread and apply a bead of threadlocker up to the top of the thread. Insert the springs into the upper handle bracket cups. Then insert the upper handle

with collars on top of the springs depressing them into the handle bracket cups and tighten the bolts to secure the handle into place. Using a torque wrench set to 132 lb/in (14.91 Nm) for stainless bolts or 251 lb/in (28.4 Nm) for black oxide bolts, tighten to the correct torque.

Perform a visual check of the post driver. Reconnect the spark plug wire to the spark plug. Check that the engine has the proper amount of oil. Start the engine using the proper procedure and test the post driver.

## Regular Service Period

Item	Each Use	First Month Or 10 Hours	Every 3 Months Or 25 Hours	Every 6 Months Or 50 Hours	Every 12 Months Or 100 Hours	Refer to Page
Engine Oil Check Level	<b>X</b>					Page 6
Engine Oil Change		<b>X</b>		<b>X</b>		Page 6
Air Cleaner Check	<b>X</b>					See Honda Engine Manual
Air Cleaner Clean			<b>X (1)</b>			See Honda Engine Manual
Air Cleaner Replace					<b>X</b>	See Honda Engine Manual
Crankcase Lubrication Check	<b>X</b>					Page 12
Check Engine and Post Diver Fasteners	<b>X</b>					Page 23
Remove, Service, Piston Hammer and Anvil					<b>X</b>	Page 13
Other Honda Engine Maintenance Schedule						See Honda Engine Manual

(1) Service more frequently when used in dusty areas.



# Rhino® Multi-Pro™ Parts and Accessories List

## Multi-Pro™ Standard Configuration

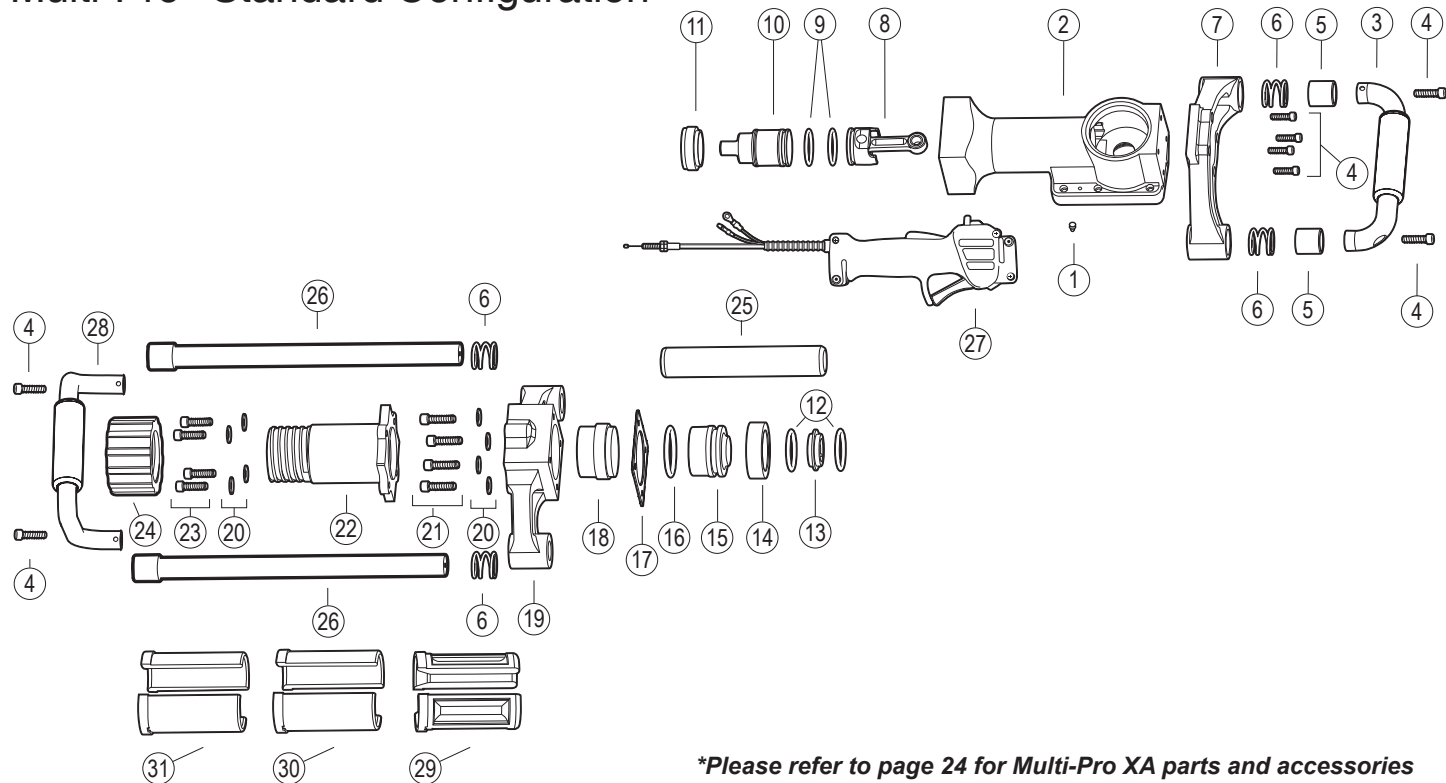

*\*Please refer to page 24 for Multi-Pro XA parts and accessories*

# Rhino® Multi-Pro™ Parts and Accessories List

No.	P/N	Description
1	300712	Ground Bolt
2	301016	Body Assembly with Cylinder and Bearings
3	301222	Top Handle Assembly
4	300715-4	Pro Series Handle Bolt (qty. of 4)
5	301221-2	Handle Collar Set (qty. of 2)
6	610010-4	Handle Springs (qty. of 4)
7	300214	Top Handle Bracket
8	301075	Piston and Connecting Rod Assembly
9	301610-2	Piston and Hammer O-ring Seal Set (qty. of 2)
10	301085	Multi-Pro™ Hammer
11	301115	Multi-Pro™ Anvil O-ring Retainer
12	301614-2	Large Retainer O-ring Seal Set (qty. of 2)
13	301105	Multi-Pro™ Large Retainer
14	301095	Multi-Pro™ Anvil O-ring Cup
15	301165	Anvil (See page 27 for Extended Anvil.)
16	301615	Multi-Pro™ Anvil O-ring Seal
17	301710	Multi-Pro™ Body Gasket
18	301038	Multi-Pro™ Sleeve for Lower Body
19	301032	Multi-Pro™ Lower Body
20	300750-4	Multi-Pro™ Lock Washers (qty. of 4)
21	300701-4	Lower Body Bolt Set (qty. of 4)

No.	P/N	Description
22	301158	Multi-Pro™ Master Chuck
23	300717-4	Multi-Pro™ Chuck Bolt Set (qty. of 4)
24	301920	Chuck-Lok™ Locking Nut (1 per driver)
25	300221	8.5" (216mm) EPDM Foam Grip (1 per driver)
26	301232	Pro-Series Side Handle Assembly
27	300250	Throttle Control Assembly
28	301233	Lower Handle Assembly
29	300900	Chuck-Lok™ System 1" (25.4 mm) Adapter
30	300895	Chuck-Lok™ System 1¼" (44.45 mm) Adapter
31	300902	Chuck-Lok™ System 2" (50.8 mm) Adapter

# Rhino® Multi-Pro™ Parts and Accessories List

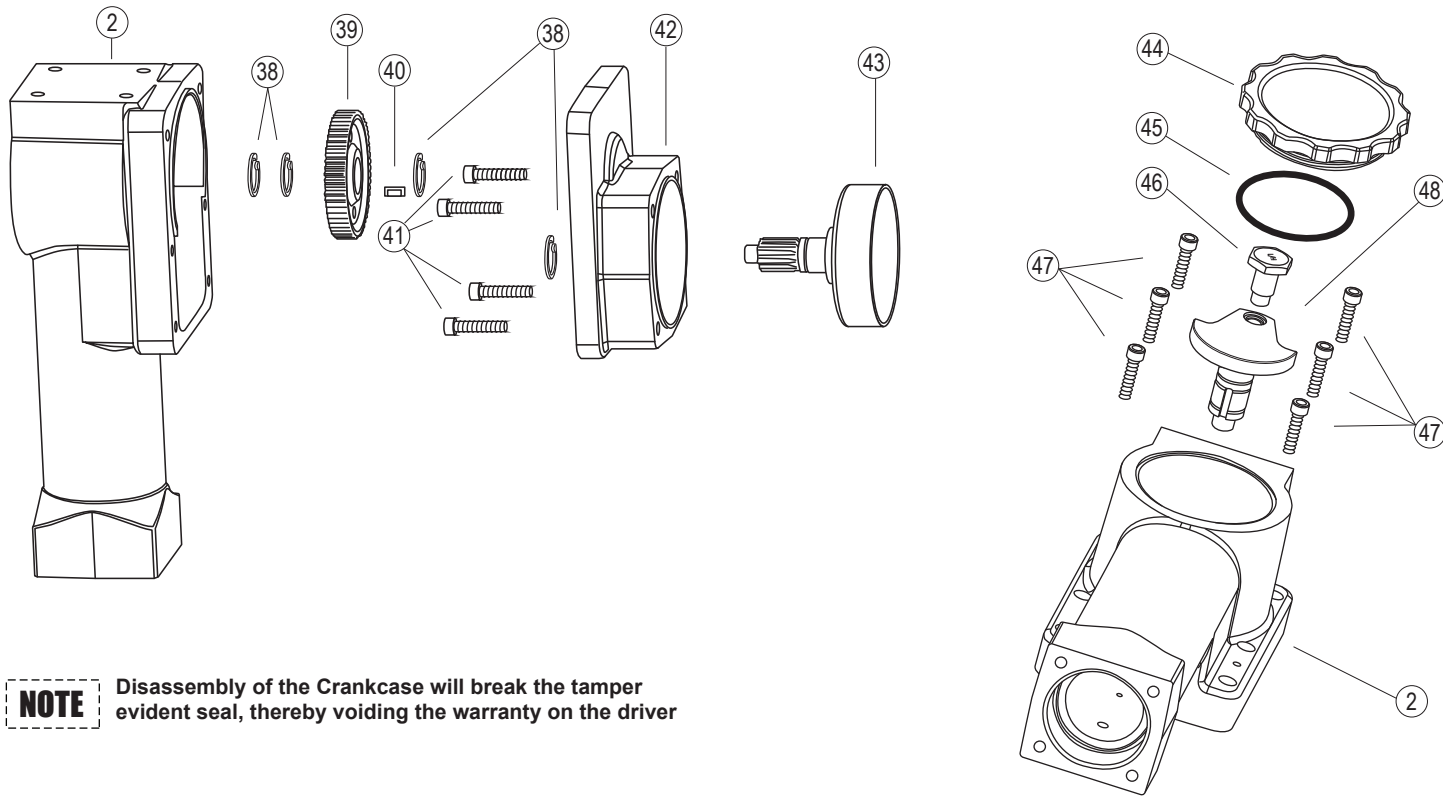

**NOTE** Disassembly of the Crankcase will break the tamper evident seal, thereby voiding the warranty on the driver



# Rhino® Multi-Pro™ Parts and Accessories List

No.	P/N	Description
2	301016	Body Assembly with Cylinder and Bearings
38	300782-4	Retaining Ring Set for Crankshaft & Clutch Drum with Pinion Gear (qty. of 4)
39	300200	Gear
40	300730	Machine Key
41	300700-4	Clutch Housing Bolt Set (qty. of 4)
42	300025	Clutch Housing with Bearings
43	300120	Clutch Drum with Pinion Gear
44	300132	Pro-Series™ Crankcase Cover - Threaded
45	301617	O-ring Seal for Pro-Series™ Crankcase Cover - Threaded
46	300050	Crank Pin (Left Hand Threads)
47	300704-6	Crankcase Bolt Set (qty. of 6)
48	300040	Crankshaft

# Rhino® Multi-Pro™ Parts and Accessories List



## Multi-Pro™ XA Lower Body Configuration\*

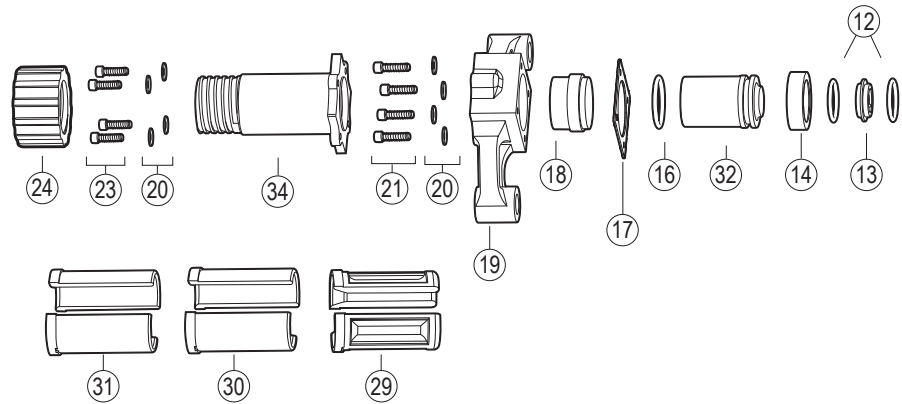

*\*Please refer to the Multi-Pro Standard Configuration for parts information on the upper portion of the Multi-Pro XA.*

# Rhino® Multi-Pro™ Parts and Accessories List

No.	P/N	Description
<b>Multi-Pro XA™ ONLY</b>		
11	301115	Multi-Pro™ Anvil O-ring Retainer
12	301614-2	Large Retainer O-ring Seal Set (qty. of 2)
13	301105	Multi-Pro™ Large Retainer
14	301095	Multi-Pro™ Anvil O-ring Cup
16	301615	Multi-Pro™ Anvil O-ring Seal
17	301710	Gasket
18	301038	Multi-Pro™ Sleeve for Lower Body
19	301032	Multi-Pro™ Lower Body
20	300750-4	Multi-Pro™ Lock Washers (qty. of 4)
21	300701-4	Lower Body Bolt Set (qty. of 4)
23	300717-4	Multi-Pro™ Chuck Bolt Set (qty. of 4)
24	301920	Chuck-Lok™ Locking Nut (1 per driver)
29	300900	Chuck-Lok™ System 1" (25.4 mm) Adapter
30	300895	Chuck-Lok™ System 1¾" (44.45 mm) Adapter
31	300902	Chuck-Lok™ System 2" (50.8 mm) Adapter
32	301169	Multi-Pro Extended Anvil
34	301420	Multi-Pro™ Extended Master Chuck

# Rhino® Multi-Pro™ Parts and Accessories List

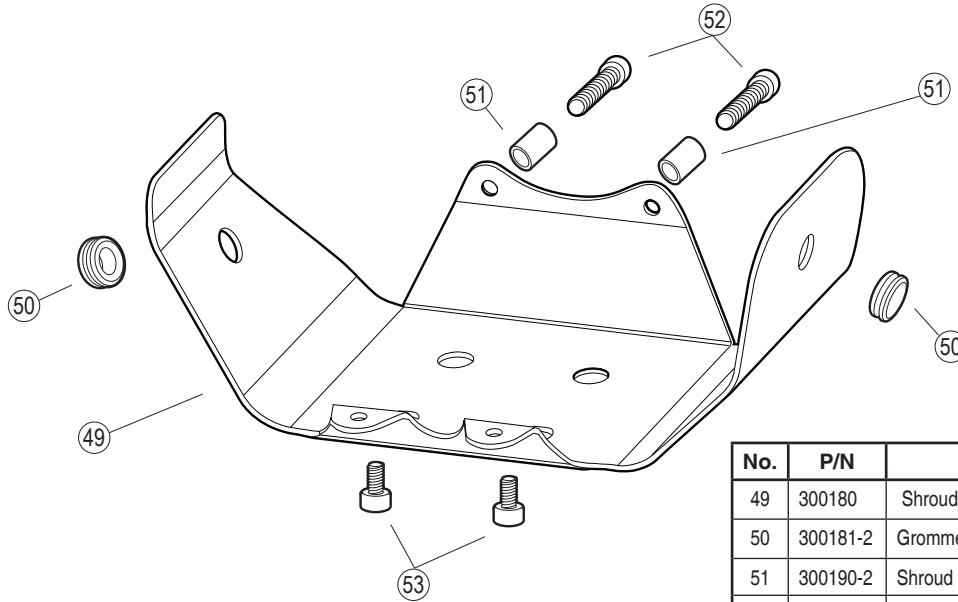

No.	P/N	Description
49	300180	Shroud
50	300181-2	Grommet (qty. of 2)
51	300190-2	Shroud Spacer (qty. of 2)
52	300706-2	Shroud Bolt (qty. of 2)
53	300705-2	Lower Shroud Bolt (qty. of 2)
	300240	Honda GX35 Engine
		Honda Engine Parts are Available from Your Local Honda Dealer
	300805	Safety Label and Tag Set
	301801	Multi-Pro™ Operating, Safety, and Parts Manual

# Rhino® Multi-Pro™ Parts and Accessories List

No.	P/N	Description
<b>Accessories</b>		
31	300902	Chuck-Lok™ System 2" (50.8mm) Adapter
30	300895	Chuck-Lok™ System 1¾" (44.4mm) Adapter
29	300900	Chuck-Lok™ System 1" (25.4mm) Adapter
24	301920	Chuck-Lok™ Locking Nut (1 required)
	301159	Multi-Pro™ Slotted Chuck
	301169	Multi-Pro™ Extended Anvil
	301175	Multi-Pro™ U-Channel Drive Kit (includes 301159, 301169)
	301155	Multi-Pro™ Tent Stake Chuck
	301400	Large Chuck Adapter (required for all large chucks) Plate*
	301171	Multi-Pro™ Square Tube Chuck
	300932	Drive cap for 1¾" (44.4mm) Square Tube**
	300933	Drive cap for 2" (50.8mm) Square Tube**
	300934	Drive cap for 2¼" (57.15mm) Square Tube**
	300935	Drive cap for 2½" (63.5mm) Square Tube**
	301403	Multi-Pro™ 3½" Round Chuck Assembly***
	301405	Multi-Pro™ 4" Round Chuck Assembly***
	301415	Multi-Pro™ 3" Square Chuck Assembly***
	301414	Multi-Pro™ 3" Round Chuck Assembly***
34	301420	Multi-Pro™ Extended Master Chuck

No.	P/N	Description
	301422	Multi-Pro™ XA Square Tube Chuck
	301000	¼" Long Arm Hex Key
	300500	Rhino® Pro Series Lubricant
	300506	Rhino® Pro Series Lubricant - 12-pack
	301509	Multi-Pro™ Service Kit
<b>Bolt Torque Specifications</b>		
4	300715-4	Pro Series Handle Bolts (qty. of 4) - 132 lb/in (14.91 Nm)
21	300701-4	Lower Body Bolts (qty. of 4) - 251 lb/in (28.3 Nm)
23	300717-4	Multi-Pro™ Chuck Bolt Set (qty. of 4) - 251 lb/in (28.3 Nm)
41	300700-4	Clutch Housing Bolt (qty. of 4) - 95.0 in/lbs (10.73 Nm)
46	300050	Crank Pin (Left Hand Threads) - 360.0 in/lbs (40.6 Nm)
47	300704-6	Crankcase Bolt (qty. of 6) - 75.0 in/lbs (8.5 Nm)
52	300706-2	Shroud Bolt (qty. of 2) - 56.4 in/lbs (6.37 Nm)
53	300705-2	Shroud Bolt - Self Tapping (qty. of 2) - 56.4 in/lbs (6.37 Nm)

\*Requires 301169 Multi-Pro™ Extended Anvil

\*\*Requires 301171 Square Tube Chuck of 301422 XA Square Tube Chuck

\*\*\*Requires 301400 Large Chuck Adapter Plate

# Rhino® Limited Lifetime Impact Warranty

## Gasoline Powered Post Drivers



**Warranty:** Rhino Tool Company, Inc. ("Rhino") warrants to the original purchaser, purchasing the Equipment in new condition, in original packaging from an authorized dealer that its Gasoline Powered Post Driver will be free from defects in workmanship and materials (the "Limited Warranty"). The Limited Warranty shall survive for the lifetime

of the product with respect to the Hammer and Anvil components and for twelve (12) months with regard to all other components, excluding the Honda GX35 engine for which Rhino provides no warranty and for which the warranty provided by American Honda Motor Co., Inc. shall be the sole warranty applicable thereto. This Limited Warranty is non-transferable.

For Warranty Claims contact your dealer or distributor. Proof of purchase date and serial number is required. In the event of a warranty repair, the post driver should be returned to a Registered and Warranty Authorized Rhino Servicing Dealer. Rhino's obligation under this Limited Warranty is expressly limited to the repair or replacement, at Rhino's election, of such defective Gasoline Powered Post Driver, which is proved to be defective upon inspection by a Rhino-certified/authorized technician.

This Limited Warranty does not extend to a Gasoline Powered Post Driver which has been subject to misuse, neglect, or accident, nor does it extend to any Gasoline Powered Post Driver which has been repaired, altered, or serviced by unauthorized persons. This Limited Warranty does not cover any damage or adjustments required to any Gasoline Powered Post Driver if such damage or adjustment is caused by the use of supplies, parts, or attachments not sold or approved by Rhino

**EXCEPT AS OTHERWISE PROVIDED HEREIN, RHINO DISCLAIMS ALL OTHER WARRANTIES, EXPRESS OR IMPLIED, INCLUDING, BUT NOT LIMITED TO THE IMPLIED WARRANTIES OF MERCHANTABILITY AND FITNESS FOR A PARTICULAR PURPOSE. UNDER NO CIRCUMSTANCES SHALL RHINO BE LIABLE FOR ANY LOSS OF BUSINESS, REVENUES, OR PROFIT OR OTHER INDIRECT, INCIDENTAL, SPECIAL OR CONSEQUENTIAL DAMAGES OR LOSS ARISING OUT OF ANY DEFECTS IN OR PERFORMANCE OF THE GASOLINE POWERED POST DRIVER, HOWSOEVER CAUSED.**

***To register your product:***

Fill out and mail in registration card supplied with post driver

***Or online visit:***

<http://rhinotool.com/contact-support/warranty-information/>

## Multi-Pro™ Trouble Shooting

**Post lodged in driver with adapter installed:** Turn off the engine. Remove the Chuck-Lok™ System's locking nut from the master chuck and slide it down the post. Using the handles, lift post driver upward, allowing the adapter to slide out. If the pressure from the flared post does not allow you to lift driver off the post, locate the pry slots on the adapter base and use a slotted screwdriver to pry them downward. Be careful not to damage the master chuck threads. Once loosened, lift using the post driver handles. As the two-piece adapter frees from the chuck tube they separate from the post. Slide the locking nut off the post, reinsert the adapter, apply the locking nut and resume post driving.

**Post lodged in master chuck:** Turn off the engine. Remove the four chuck bolts and separate the master chuck from lower body. Slide the master chuck down the post to expose the flared top of the post. With the proper cutting tool for the type of post, cut through the post below the flared portion. Once the flared portion is removed, slide the master chuck off the post and reassemble the chuck to the driver. Please follow bolt tightening procedure and use threadlocker solution.

**Recommendation:** Do not use "thin-wall" or light gauge round post with the Multi-Pro™. It is very likely to flare this type of post at full throttle.

**Drives post slow or sluggish engine performance:** Typically this is resulting from improper driver storage or over-filling the oil causing the oil to seep into the combustion chamber. Turn off the engine. Position the driver vertically; remove the dipstick to check oil level. (See page 6) If you need to remove some oil, dispose of it properly. If oil is at proper level, follow the procedure listed in "Pull-start is frozen or hard to pull."

**Pull-start is frozen or hard to pull:** This typically results from oil seeping into the combustion chamber from improper driver storage or overfilling the oil reservoir of the engine. Remove spark plug and pull hand grip a several times until it pulls freely. Replace the spark plug. Check the oil level in oil reservoir to ensure proper level (page 6). Follow starting procedure. It is not unusual, for blue smoke to be emitted from the engine, let the engine run until smoke clears.

**Proper Storage:** When storing your Multi-Pro, do not lay it horizontally on the driver side or resting on the engine. If the unit cannot be stored securely in the upright position, place the chuck on the flat surface, lean it toward the engine side until it is supported by the shroud and chuck. This will position the driver on an angle with the top handle at the topmost point. It is suggested to clean the engine and driver after each use.

**Other problems or technical questions:** Document your serial number and contact Rhino Tool Company. Phone: 309.853.5555 or Toll Free 866-707-1608, Fax:309.856.5905, Email: [info@rhinotool.com](mailto:info@rhinotool.com).

## Manufacturing Quality Post Drivers and Post Pullers Since 1975



**Driven To**  
*Perfection!*



CE

© 2016 Rhino Tool Company, Inc.

Rhino Tool Company, Inc.

620 Andrews Avenue

Kewanee, IL 61443

P: 309-853-5555 or Toll Free 866-707-1808

F: 309-856-5905

www.rhinotool.com E: info@rhinotool.com