



WL60T

Telescopic Wheel Loaders



Articulated wheel loader with telescopic boom - WL60T

The WL60T telescopic wheel loader is equipped with a 101-hp turbo charged Perkins diesel engine and features a telescopic boom for additional height, added versatility and greater production. With the 1.5 cubic yard bucket capacity and class leading 16 ft. 8 in. bucket pin height, the WL60T is optimal for loading high-sided trucks and feed bins. Operating elements such as the multi-functional joystick allow the operators to control machine direction, differential lock, auxiliary electronics and auxiliary hydraulics without having to remove their hand from the control.

- Telescopic lift arm delivers 16 ft. 8 in. pin height to easily manage high sided trucks and material containers
- Universal hydraulic attachment plate along with 26 gpm auxiliary hydraulic flow accommodates most existing skid steer attachments
- Excellent service access with tilting cab and engine hood that opens 90-degrees, allowing full access to all engine and hydraulic components
- 101 hp Perkins turbo charged diesel engine provides power and speed to maximize efficiency



Technical specifications

Engine / Motor

| | |
|-----------------------------|-----------------------|
| Engine / Motor manufacturer | Perkins |
| Engine / Motor type | 854E-E34TAWF |
| Cylinder | 4 |
| Engine performance | 100.5 hp |
| at rpm | 2,500 rpm |
| Displacement | 207.4 in ³ |
| Coolant type | Water / Charge air |

Electrical system

| | |
|-------------------|-------|
| Operating voltage | 12 V |
| Battery | 95 Ah |
| Alternator | 120 A |

Operating data

| | |
|--|--|
| Operating weight | 14,323 lb |
| Speed - standard | 0-12.4 mph |
| Speed - optional | 0-19 mph |
| Bucket capacity | 1.5 yd ³ |
| Payload | 7,433.9 lb |
| Tipping load with bucket - machine straight | 7,433.9 lb |
| Tipping load with pallet fork - machine straight | 6,990.8 lb |
| Standard tires | 600/40-22.5 AS ET-50 |
| Service brake | disc brakes |
| Traction drive | Hydrostatic with universal joint shaft |
| Axles | PA 1422 |

Steering and operating hydraulics

| | |
|---|-------------|
| Driving hydraulics - operating pressure | 6,454.3 psi |
| Operating hydraulics - operating pressure | 3,408.4 psi |
| Operating hydraulics - discharge capacity | 26 US gpm |
| Steering angle | 42 ° |

Filling capacities

| | |
|----------------------------------|-------------|
| Fuel tank capacity | 27.3 US gal |
| Hydraulic oil tank | 100.3 US qt |
| Average sound power level LwA | 101 dB(A) |
| Guaranteed sound power level LwA | 103 dB(A) |



**WACKER
NEUSON**
all it takes!

Specified sound pressure level LpA

78 dB(A)



**WACKER
NEUSON**
all it takes!

Dimensions

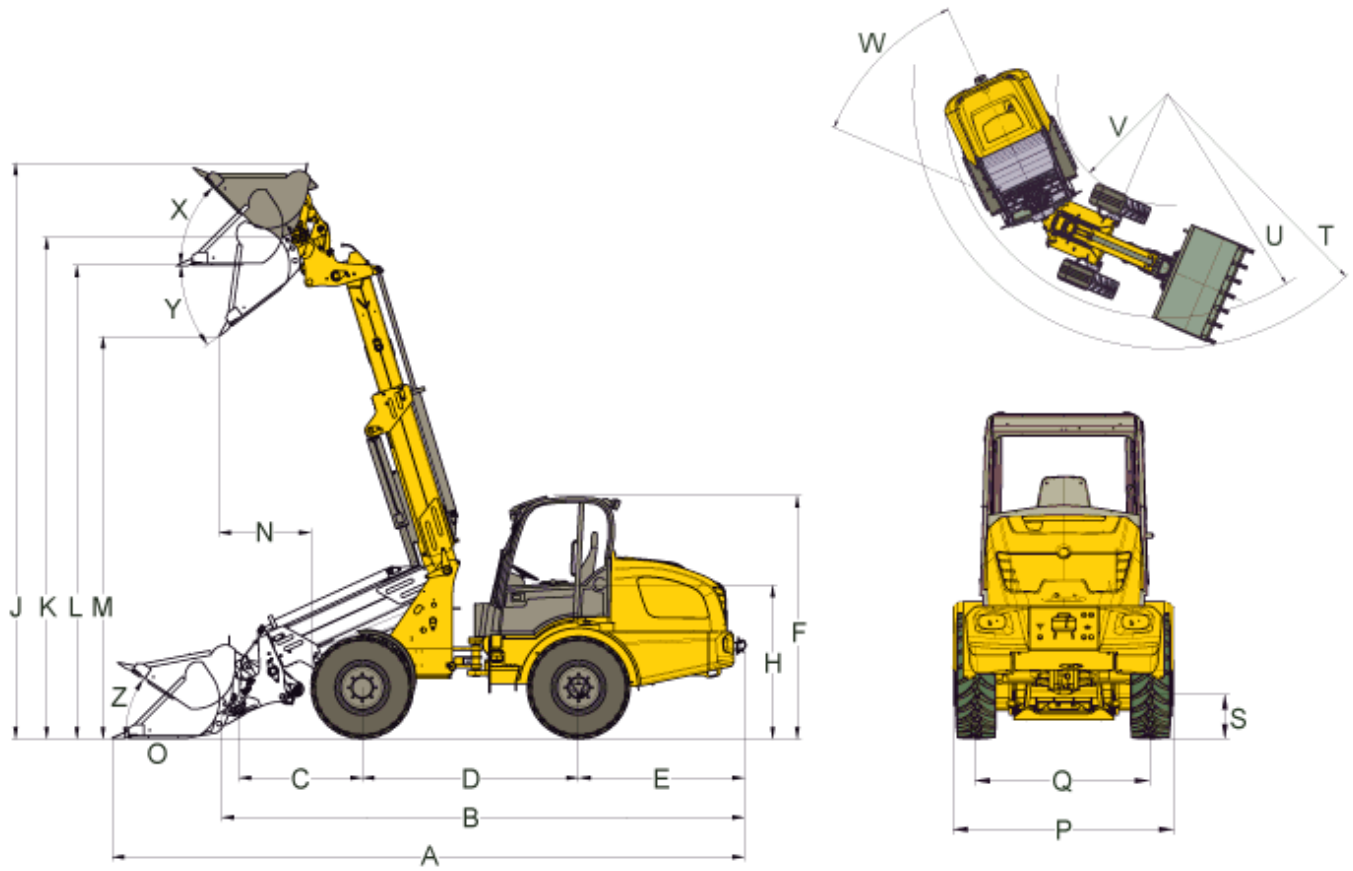

| | | |
|---|-----------------------------------|----------|
| A | Overall length | 251.8 in |
| B | Overall length without bucket | 204.7 in |
| P | Overall width | 83.5 in |
| S | Ground clearance | 14.2 in |
| C | Bucket pivot point to axle center | 49 in |
| D | Wheelbase | 86.2 in |
| E | Rear overhang | 66 in |
| F | Cabin height | 105.5 in |
| H | Seat height | 63.3 in |
| J | Total operating height | 229.3 in |



**WACKER
NEUSON**
all it takes!

| | | |
|---|---|----------|
| K | Stroke height max. - bucket pivot point | 199.8 in |
| L | Overhead loading height | 188.6 in |
| M | Dump height max. | 160.3 in |
| N | Dump reach at M | 36.7 in |
| Q | Track width | 56 in |
| T | Radius maximum | 177.6 in |
| U | Radius at outer edge | 154.7 in |
| V | Inside turning radius | 76.8 in |
| W | Articulation angle | 42 ° |
| X | Bucket rollback at max. stroke height | 45 ° |
| Y | Dump angle | 33 ° |
| Z | Bucket rollback at ground level | 41 ° |

Please note

that product availability can vary from country to country. It is possible that information / products may not be available in your country. More detailed information on engine power can be found in the operator's manual; the stated power may vary due to specific operating conditions.

Subject to alterations and errors excepted. Applicable also to illustrations.

Copyright © 2017 Wacker Neuson SE.



Blanchard Machinery Inc.
1890 N.E. 150 Street
North Miami Fla. 33181
bmisalz@aol.com
www.blanchardmachinery.net