

Wheel loaders

All-wheel steer • Articulated • Telescopic



**WACKER
NEUSON**
all it takes!

**Blanchard
Machinery**



RENTAL / SALES / SERVICE



Wacker Neuson's full line of wheel loaders — load more, move it faster, place it anywhere.

All-wheel steer, articulated and telescopic wheel loaders have the power, performance and operator comfort to tackle any job and quickly and precisely manage all types of loads. All models come with a hydraulically operated universal attachment plate allowing you to go beyond the bucket. Quickly change any of your current or new attachments, making wheel loaders the perfect year-round job site solution.

All-wheel steer - One-piece chassis and fixed center of gravity allow for constant payloads and increased stability.

Articulated - The articulated joint makes these units highly maneuverable, especially in tight working conditions.

Telescopic - Achieve additional reach for stacking and dumping with a telescopic boom. Available in articulated and all-wheel steer versions.



All-wheel steer wheel loaders

The all-wheel steering angle of 40 degrees on each axle allow you a high degree of maneuverability. This makes turning easy and shortens traveling and cycle times.



Articulated wheel loaders

Tight curves, small gradients – every construction site is different. The articulated joint provides for the best maneuverability for you to work efficiently tight spaces.



Telescopic wheel loaders

Telescopic boom wheel loaders offer additional height, added versatility and greater productivity.

Wheel loader model overview.

ALL-WHEEL STEER



S055

Tip load straight bucket:

4,365 lbs



S085

8,047 lbs



S085T

7,275 lbs

ARTICULATED



WL32

Tip load straight bucket:

5,002 lbs

Tip load fully articulated bucket:

4,184 lbs



WL34

5,919 lbs

4,969 lbs



WL38

6,576 lbs

5,498 lbs

Wheel loader expertise down to the last detail.

Wheel Loaders will save you money

Automotive style controls allow the wheel loader engine to only produce the power when needed. Reduced engine rpm produces substantial fuel savings and increase life the engine.



WORK CYCLE

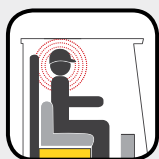
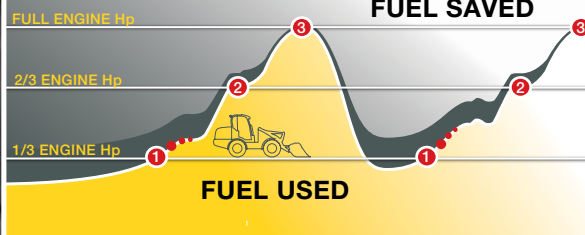

Ergonomic cab design

Spacious cab and easily accessible controls ensure operator comfort and convenience.

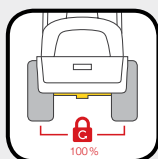

100% engageable differential lock

Maximum traction, even on difficult surfaces, is made possible with the 100% engageable differential lock.

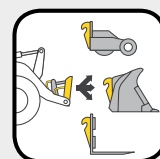

One connection, countless attachments

Use wheel loaders for any task. Standard hydraulic attachment plate (SSL) provides added versatility.



8115L

9,480 lbs



Wacker Neuson and the EPA's Clean Air Act.

At Wacker Neuson, we have always made it a priority to design and build equipment with the customer as well as the environment in mind. That's why Wacker Neuson material handling equipment is built in compliance with the EPA's Clean Air Act and the stringent requirements for off-road diesel engines.



WL52

7,083 lbs
5,983 lbs



WL60

8,100 lbs
6,682 lbs



WL60T

7,434 lbs
6,250 lbs



All-wheel steer wheel loaders

The all-wheel steer (AWS) wheel loaders are designed with a rigid one-piece chassis that prevents shifts in the center of gravity even at full turn. This ensures unparalleled stability, even when working on uneven ground and maintains a constant payload. The AWS has a 40-degree steering angle on each axle that allows a high degree of maneuverability which helps to reduce transit and cycle times.

Turning is easy with a one-piece chassis for a high level of stability.

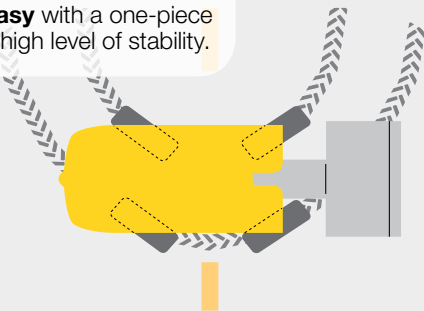

Designed for a constant payload because the center of gravity remains in the middle of machine.

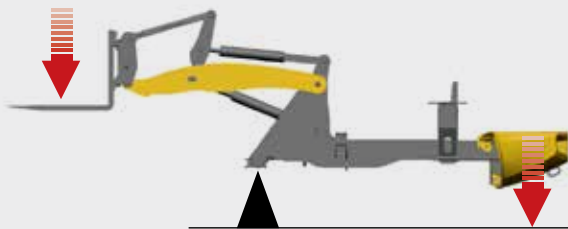
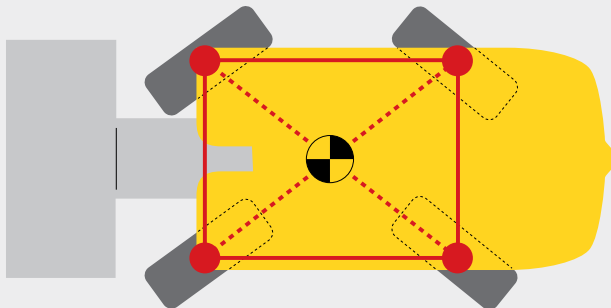

Three types of steering

Select AWS models feature three steering modes that are electronically synchronized and provide maximum maneuverability on any job site. Changes in steering modes can be made while the machine is in motion allowing for smooth transition.

4-wheel: Tight turning radius is ideal for maneuvering in confined areas and job sites with obstructions.

2-wheel: Operates like a car with only front wheels steering. For applications where pushing is required and for faster forward travel times.

Crab: Both front and rear wheels turn in the same direction allowing for lateral operation. For areas where tight access such as against walls is needed.



4-wheel



2-wheel



Crab

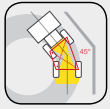

Articulated wheel loaders

When working in confined areas with tight turns and uneven terrain, articulated wheel loaders are an excellent choice. The articulated joint allows the machine to access and operate in areas such as residential spaces, greenhouses and barns. The high degree of maneuverability and stability allow materials to be transported more efficiently.

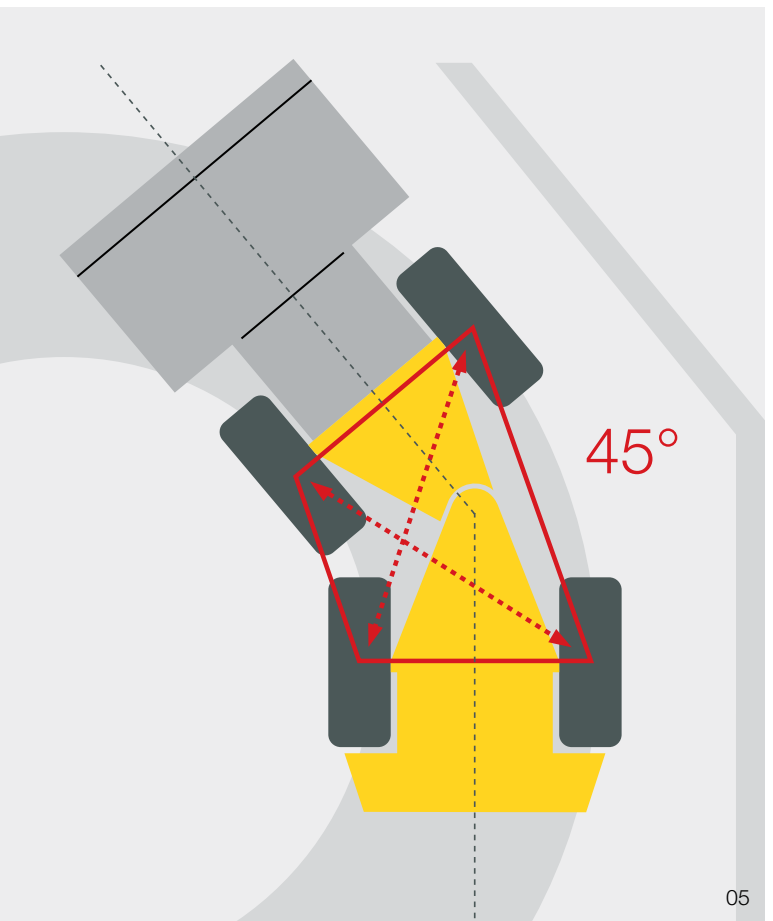



Differential lock

The 100% differential lock can be manually engaged with the push of a button, making it possible to work reliably on difficult surfaces.

The lock is not engaged during normal driving operation. This prevents unnecessary tire wear, while protecting the surface.



The differential lock is easily engaged only as you need it.

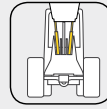

Two lift cylinders

For even greater stability of the loading system, all Wacker Neuson wheel loaders are equipped with two lift cylinders. This optimizes weight distribution on the load arm.



Inch-brake pedal

Operate the hydraulics at full power, while reducing the travel speed with one pedal. You can regulate both mechanical as well as hydraulic braking ("inching") via the inch-brake pedal.

Advantages include less wear on the service brake, as well as optimal performance distribution of the engine output.

Inch-brake pedal: Engine output where it's needed.

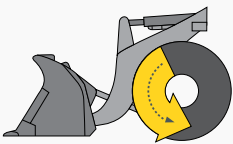

No pressure on the inch-brake pedal: full power for the travel drive.

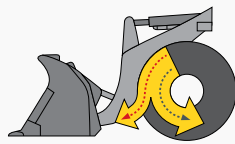

Slight pressure on the inch-brake pedal: the speed is reduced, more power to the work hydraulics.

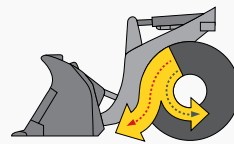

Strong pressure on the inch-brake pedal: the speed is reduced further, even more power to the work hydraulics.

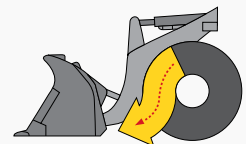

Full pressure on the inch-brake pedal: the wheel loader stands still, full power to the work hydraulics.

Attachments

Articulated and all-wheel steer wheel loaders come with a universal hydraulic attachment plate that enables the operator to quickly switch attachments without leaving the operator's station. The Faster hydraulic block and 14-pin auxiliary electrical harness allow you to easily use your current or new skid steer attachments for added cost savings and versatility.

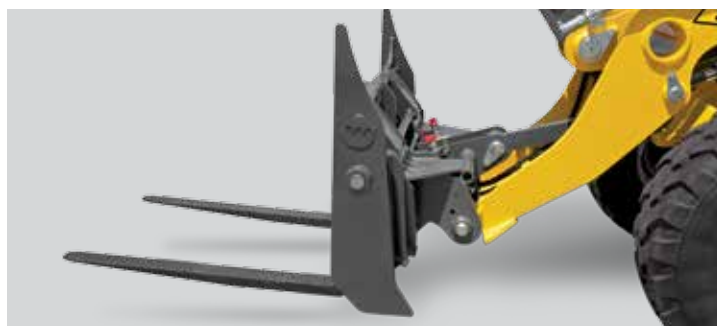

Maintenance

Easy access to hydraulics, engine and air filter. Depending on the model, you only need to carry out a few steps with the laterally tilting cab as well as easy-to-open service access doors. Quick maintenance reduces downtime and saves you money.



Long service life

You can rely on the best quality down to the last detail. A high material thickness on the load arms ensures reliable stability. The powder-coating also makes it sturdy against mechanical impacts and corrosion.

Comfort

Operator comfort is the foundation of the wheel loaders' design. Plenty of legroom, adjustable seats, ergonomically positioned controls at the operators' fingertips and excellent visibility all contribute to longer, productive operation. Depending on the model, there are a variety of comfort features to meet the needs of the job and operator.

Ergonomic and spacious



Multifunction joystick

Control direction, differential lock, auxiliary electronics and auxiliary hydraulic functions of the machine with one simple joystick.

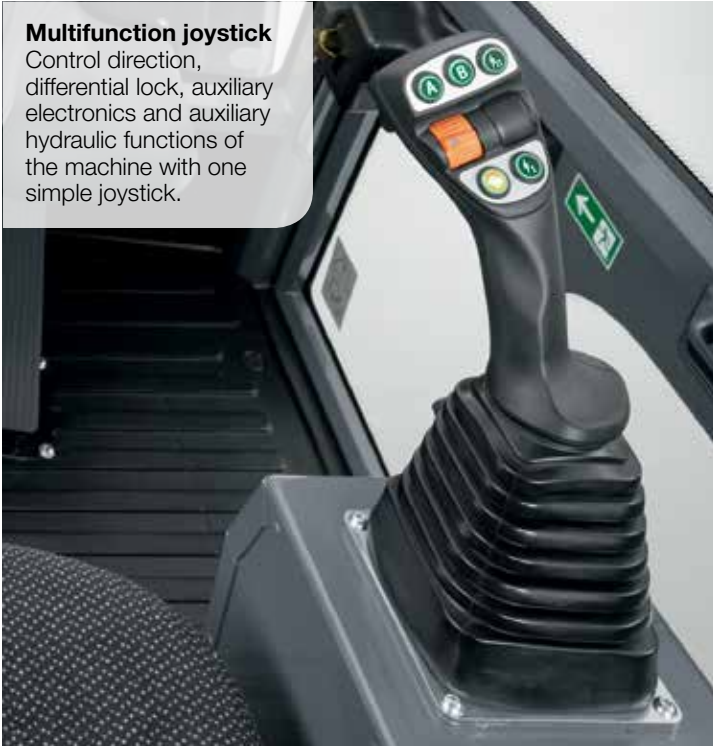

Comfortable for any operator

Adjustable features to accommodate operators of all sizes. Heat and air-conditioning are available in most models.



Panoramic 360° view

Large glass windows provide an unobstructed view of the job site and attachment.





Canopy and Cab

Wacker Neuson wheel loaders are available with open canopy and enclosed cab operating platforms (depending on model). All loaders are perfectly designed for the requirements of everyday construction site life and meet high safety standards.

- ROPS-protection (roll-over protective structure)
- FOPS-protection (falling object protective structure)



Enclosed cab



Open ROPS canopy



5055

The 5055 all-wheel steer wheel loader delivers an exceptional power-to-weight ratio, making it an ideal all purpose tool carrier for a variety of applications. The machine features a long wheelbase for smooth driving and easy handling even across the roughest terrain. Counterweights are located far behind the rear axle for higher payloads and added stability.

- Safety, comfort and a variety of options
- All-wheel steering and an undivided chassis for outstanding stability
- A long service life and economic efficiency
- Canopy and cab versions available

5055

Operating weight	7,606 lbs
Engine output	47 hp
Tip loads straight (bucket/forks)	4,365 / 4,409 lbs
Operating capacity (bucket/forks) hard surface (80%)	3,492 / 3,527 lbs
Operating capacity (bucket/forks) rough terrain (60%)	2,619 / 2,646 lbs



Multi-purpose model

ideal for a variety of applications.

Safer material handling with maximum stability.



8085

The 8085 wheel loader offers speed, versatility, stability and operator comfort on any job site. The 8085 is an ideal machine where continuous travel over longer distances is needed, reducing cycle time and improving productivity. This unit features a long wheelbase for smooth driving and easy handling even across the roughest terrain.

- Two speed configurations: standard 12.4 mph/19 gpm; optional high speed/high flow: 25 mph/30 gpm
- All-wheel drive steering offers excellent maneuverability, overall machine stability and increased payloads
- Three-mode steering
- Sturdy load arm design



High load-carrying capacity easily places loads at any height.

8055	
Operating weight	10,742 lbs
Engine output	74 hp
Tip loads straight (bucket/forks)	8,047 / 5,926 lbs
Operating capacity (bucket/forks) hard surface (80%)	6,437 / 4,740 lbs
Operating capacity (bucket/forks) rough terrain (60%)	4,828 / 3,556 lbs



ALL-WHEEL STEER

8085T

The 8085T telescopic wheel loader offers reach and stability in one machine. The telescopic boom can reach over 15', allowing for endless applications of loading, stacking and dumping materials. The all-wheel steer design with constant center of gravity keeps the machine stable even when turning at full load.

- Tier 4 Final engine with maintenance-free DOC aftertreatment
- Three-mode steering
- Standard and optional high speed/high flow increases versatility
- Long wheel base for smooth driving and easy handling



8085T

Operating weight	12,125 lbs
Engine output	74 hp
Tip loads straight (bucket/forks)	7,275 / 5,512 lbs
Operating capacity (bucket/forks) hard surface (80%)	5,820 / 4,409 lbs
Operating capacity (bucket/forks) rough terrain (60%)	4,365 / 3,307 lbs

Reach new heights: telescopic boom reaches 15' 4" to the hinge pin.

Within reach – the 8085T can get the job done.



8115L

The 8115L offers the power and capacity for larger jobs, but has a compact design to access hard-to-reach areas. The pressurized, enclosed cab is designed for maximum operator comfort and efficiency.

- 100 hp engine provides power for lifting and hydraulic performance
- All-wheel steer with rigid frame provides stability and constant payload
- Load high-sided trucks and bins with 11' 11" hinge pin height
- Optional 25 mph reduces cycle times (12 mph standard)

8115L

Operating weight	13,338 lbs
Engine output	100 hp
Tip loads straight (bucket/forks)	9,480 / 7,992 lbs
Operating capacity (bucket/forks) hard surface (80%)	7,584 / 6,393 lbs
Operating capacity (bucket/forks) rough terrain (60%)	5,688 / 4,795 lbs



Versatility - universal attachment plate for all your tools.



**Comfort and speed
improve cycle times
and productivity.**

Wheel loaders - fit for any job, any season.

Wacker Neuson's range of hard-working wheel loaders are the ideal material handling machines no matter what the terrain or time of year. From the construction and landscape season to snow removal season, our wheel loaders have the power, endurance, agility and visibility to manage any material. But these multifunctional tool carriers can easily go beyond the bucket. The universal attachment plate on every machine works with all your tools, taking versatility to a new level.

Powerful hydraulics: perfect for applications with a sweeper or snow blower.



Telescopic wheel loaders provide versatility when and where you need it most.



Reliable load carrier – and always with a good view of the transport material.





Trailer coupling for the transport of construction site equipment, such as a light tower.



Two sturdy lift cylinders can take even large bucket volumes safely from A to B.



ARTICULATED

WL32

There are bottlenecks on virtually every construction site, but you can go everywhere easily with the WL32. This compact wheel loader is not only extremely maneuverable, it is designed to fit in very confined spaces. Optional narrow tires are ideal for sidewalks.

- Compact dimensions in width and height
- Easy maneuvering due to the tight turning radius
- Powerful hydraulic system and matched engine output
- Standard auxiliary hydraulic flow of 16 gpm, optional 28 gpm high flow
- Comfortable operator's station
- Available with canopy or cab

Easy to transport: suitable for trailers due to low weight and compact design.



WL32

Operating weight	7,496 lbs
Engine output	48 or 60 hp
Tip loads straight (bucket/forks)	5,002 / 4,206 lbs
Tip loads fully-articulated (bucket/forks)	4,184 / 3,538 lbs
Operating capacity fully-articulated (bucket/forks) hard surface (80%)	3,347 / 2,831 lbs
Operating capacity fully-articulated (bucket/forks) rough terrain (60%)	2,511 / 2,123 lbs

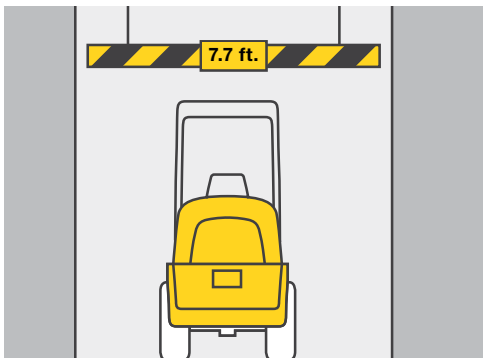

Easy garage or building clearance: low passageways are not an obstacle.



Year-round application – e.g., with a snow blower in the winter.

WL34

The combination of power, performance and operator comfort make the WL34 a versatile wheel loader for any application, including confined areas.

- Very compact dimensions
- Canopy and cab versions available
- Standard auxiliary flow of 16 gpm
- Fertilizer version includes standard kinematics adapter and optional Nyalic® anti-corrosion coating

WL34

Operating weight	7,584 lbs
Engine output	48 hp
Tip loads straight (bucket/forks)	5,915 / 4,941 lbs
Tip loads fully-articulated (bucket/forks)	4,969 / 4,145 lbs
Operating capacity fully-articulated (bucket/forks) hard surface (80%)	3,975 / 3,316 lbs
Operating capacity fully-articulated (bucket/forks) rough terrain (60%)	2,981 / 2,487 lbs



Optimized performance
for unique applications.

Fertilizer edition withstands harsh environments.



WL38

The WL38 is a versatile wheel loader that is compact yet powerful, with the ability to achieve top speeds up to 19 miles hour, for improved cycle times. The deluxe cab is ergonomically designed for comfort and convenience and includes factory installed heat and air conditioning.

- Small footprint, but has the power of a larger wheel loader
- Standard auxiliary hydraulic flow of 18 gpm and high flow of 33 gpm allows the operation of high performance attachments
- Convenient multifunctional single lever control and additional lever for third control circuit
- Special 60 hp fertilizer edition available

WL38

Operating weight	9,480 lbs
Engine output	60 or 74 hp
Tip loads straight (bucket/forks)	6,576 / 5,666 lbs
Tip loads fully-articulated (bucket/forks)	5,498 / 4,791 lbs
Operating capacity fully-articulated (bucket/forks) hard surface (80%)	4,398 / 3,832 lbs
Operating capacity fully-articulated (bucket/forks) rough terrain (60%)	3,298 / 2,875 lbs



Compact dimensions –
perfect for those tight areas.



High speed,
high flow for
maximum
performance.

WL52

The WL52 is the ideal machine for a variety of applications. Power and performance, plus travel speeds up to 19 mph mean getting around the jobsite is extremely efficient. Working longer hours is much easier to handle with many operator comfort features, including standard heat and air conditioning.

- Powerful Tier 4 Final engine with zero maintenance, DOC aftertreatment
- Standard auxiliary hydraulic flow of 18 gpm and high flow of 33 gpm
- Smooth and effortless joystick pilot control for fatigue-free operation
- Driver's cab tilts for easy service access

WL52

Operating weight	11,244 lbs
Engine output	74 hp
Tip loads straight (bucket/forks)	7,083 / 5,986 lbs
Tip loads fully-articulated (bucket/forks)	5,983 / 5,079 lbs
Operating capacity fully-articulated (bucket/forks) hard surface (80%)	4,786 / 4,063 lbs
Operating capacity fully-articulated (bucket/forks) rough terrain (60%)	3,589 / 3,047 lbs



Versatile powerhouse –
plenty of power for any task.

Multiple uses from the farm to construction site.



ARTICULATED

WL60

With the combination of power, speed and maneuverability, the WL60 is built for material handling and high performance attachments. Class-leading hinge pin height of 12' easily manages dumping loads over high-sided trucks.

- Standard auxiliary hydraulic flow of 26 gpm and optional high flow of 40 gpm
- Spacious climate controlled cab features impressive 360° visibility
- Standard air-ride seat and ergonomically designed controls
- Excellent service access with tilting cab

WL60

Operating weight	13,007 lbs
Engine output	102 hp
Tip loads straight (bucket/forks)	8,100 / 7,372 lbs
Tip loads fully-articulated (bucket/forks)	6,682 / 6,153 lbs
Operating capacity fully-articulated (bucket/forks) hard surface (80%)	5,346 / 4,923 lbs
Operating capacity fully-articulated (bucket/forks) rough terrain (60%)	4,010 / 4,693 lbs



Two configurations:

12 mph / 26 gpm flow or 19 mph / 26 gpm flow with optional 40 gpm.



Get those tough jobs done the right way in comfort.



WL60T

The WL60T features stable and maneuverable operation, especially in tight spaces, plus additional reach with a telescopic boom. The telescopic arm delivers 16' 8" hinge pin height to easily manage high-sided trucks and material containers, providing added versatility and greater production.

- Power, speed and maneuverability make material handling jobs easy
- Use most attachments with universal hydraulic attachment plate along with 26 gpm auxiliary hydraulic flow
- Multifunctional joystick allows operators to control machine direction, differential lock, auxiliary electronics and auxiliary hydraulics
- Excellent service access with tilting cab



Additional reach

Class-leading 16' 8" hinge pin height.

	WL60T
Operating weight	13,448 lbs
Engine output	102 hp
Tip loads straight (bucket)	7,434 / 4,211 lbs
Tip loads straight (forks)	7,020 / 4,239 lbs
Tip loads fully-articulated (bucket)	6,250 / 3,499 lbs
Tip loads fully-articulated (forks)	5,900 / 3,525 lbs
Operating capacity fully-articulated (bucket) hard surface (80%)	5,000 / 2,800 lbs
Operating capacity fully-articulated (forks) hard surface (80%)	4,718 / 2,820 lbs
Operating capacity fully-articulated (bucket) rough terrain (60%)	3,750 / 2,099 lbs
Operating capacity fully-articulated (forks) rough terrain (60%)	3,538 / 2,114 lbs

retracted / extended

You have the options you want with the power you need.



Standard equipment and options

ALL-WHEEL STEER WHEEL LOADERS

	5055	8085	8085T	8115L
ENGINE				
Perkins 404F-22 49 hp	-	-	-	-
Perkins 404F-22T 60 hp	-	-	-	-
Deutz TCD 2.9 L4 74 hp	-	●	●	-
Perkins 854E 101 hp	-	-	-	-
Yanmar 4NNKAC Tier IV Final 47 hp	●	-	-	-
Deutz TCD 3.6 100 hp	-	-	-	●
Tier 4 Interim engine	-	-	-	-
CAB TYPE				
Cab with heat only	-	-	-	-
Cab with heat and a/c	○	●	●	●
Canopy	○	-	-	-
HYDRAULICS				
Ride control	-	○	○	○
High flow	○	○	○	○
20 kph travel speed (12 mph)	○	○	○	○
30 kph travel speed (19 mph)	○	-	-	-
40 kph travel speed (25 mph)	-	○	○	○
Universal hydraulic attachment plate (SSL)	●	●	●	●
14-pin auxiliary electric / hydraulic control	●	●	●	●
Fertilizer package	-	-	-	-
FEATURES				
Nyalic® anti-corrosion option	●	●	●	●
Connect under pressure Faster block	●	●	●	●
Front / rear work lights	●	●	●	●
Boom float only	●	●	●	●
Bucket / boom float	-	-	-	-
Spring suspension seat	●	-	-	-
Air ride suspension seat	-	●	●	●
Manual speed and throttle controls	○	○	○	○
Ride control	○	○	○	○
DEALER INSTALL KITS				
Manual speed control	●	-	-	-
Manual throttle control	●	-	-	-
Manual speed and manual throttle control	-	●	●	●
Salt spread mount	-	●	●	●
Block heater	●	-	-	-
Hydraulic valve	-	-	-	-
Kinematic	-	-	-	-
Rotating beacon	●	●	●	●
Rotating LED beacon	-	●	●	●
LED working lights	-	●	●	●
Protective front windshield	-	●	●	●

● Standard feature ○ Available on select configurations only

	WL32	WL34	WL38	WL52	WL60	WL60T
ENGINE						
Perkins 404F-22 49 hp	○	●	-	-	-	-
Perkins 404F-22T 60 hp	○	-	○	-	-	-
Deutz TCD 2.9 L4 74 hp	-	-	○	●	-	-
Perkins 854E 101 hp	-	-	-	-	●	●
Yanmar 4NNKAC Tier IV Final 47 hp	-	-	-	-	-	-
Deutz TCD 3.6 100 hp	-	-	-	-	-	-
Tier 4 Interim engine	-	-	-	-	●	●
CAB TYPE						
Cab with heat only	-	○	-	-	-	-
Cab with heat and a/c	○	-	●	●	●	●
Canopy	○	○	-	-	-	-
HYDRAULICS						
Ride control	-	-	○	○	○	○
High flow	○	-	○	○	○	-
20 kph travel speed (12 mph)	●	●	○	○	○	○
30 kph travel speed (19 mph)	-	-	○	○	○	○
40 kph travel speed (25 mph)	-	-	-	-	-	-
Universal hydraulic attachment plate (SSL)	●	●	●	●	●	●
14-pin auxiliary electric / hydraulic control	●	●	●	●	○	-
Fertilizer package	-	○	○	-	-	-
FEATURES						
Nyalic® anti-corrosion option	●	●	●	●	●	●
Connect under pressure Faster block	●	●	●	●	●	●
Front / rear work lights	●	●	●	●	●	●
Boom float only	-	●	●	●	●	●
Bucket / boom float	●	-	-	-	-	-
Spring suspension seat	●	●	●	●	-	-
Air ride suspension seat	-	-	-	-	●	●
Manual speed and throttle controls	-	-	-	-	-	-
Ride control	-	-	○	○	○	○
DEALER INSTALL KITS						
Manual speed control	●	-	●	●	●	●
Manual throttle control	●	●	●	●	●	●
Manual speed and manual throttle control	-	-	-	-	-	-
Salt spread mount	●	●	●	●	●	●
Block heater	●	●	-	-	-	-
Hydraulic valve	●	●	-	-	-	-
Kinematic	-	●	●	-	-	-
Rotating beacon	-	-	-	-	-	-
Rotating LED beacon	-	-	-	-	-	-
2 front LED working lights	-	-	-	-	-	-
Protective front windshield	-	-	-	-	-	-

Technical data

WHEEL LOADER

		5055	8085	8085T	8115L
ENGINE		ALL-WHEEL STEER WHEEL LOADERS			
ENGINE	UNIT				
Manufacturer	-	Yanmar	Deutz	Deutz	Deutz
Max. engine output option	hp (kW)	47 (35)	74.3 (55.4)	74.3 (55.4)	99.7 (74.4)
at max. RPM	rpm	2,400	2,300	2,300	2,300
Displacement	in ³ (l)	134 (2.2)	177 (2.9)	177 (2.9)	219 (3.6)
WEIGHTS		UNIT			
Operating weight*	lb (kg)	7,606 (3,450)	10,472 (4,750)	12,125 (5,550)	13,338 (6,050)
Bucket breakaway force maximum (according to ISO 14397-2)	lbf	6,295	9,172	11,016	9,419
Bucket capacity**	yd ³ (m ³)	0.72 (0.55)	1.11 (0.85)	1.11 (0.84)	1.5 (1.15)
Straight tipping load (bucket / fork)	lb (kg)	4,365 (1,980) / 4,409 (2,000)	8,047 (3,650) / 5,926 (2,688)	7,275 (3,300) / 5,512 (2,500)	9,480 (4,300) / 7,992 (3,625)
Articulated tipping load (bucket / fork)	lb (kg)	-	-	-	-
Operating capacity (bucket / fork)	lb (kg)				
- hard surface (80%)		3,492 (1,584) / 3,527 (1,600)	6,437 (2,920) / 4,828 (2,190)	5,820 (2,640) / 4,409 (2,000)	7,584 (3,440) / 6,393 (2,900)
- rough terrain (60%)		2,619 (1,188) / 2,646 (1,200)	4,740 (2,150) / 3,556 (1,613)	4,365 (1,980) / 3,307 (1,500)	5,688 (2,580) / 4,795 (2,175)
- fully articulated hard surface (80%)		-	-	-	-
- fully articulated rough terrain (60%)		-	-	-	-
- fully art. hard surface, boom retr. (80%)		-	-	-	-
- fully art. rough terrain, boom retr. (60%)		-	-	-	-
Travel speed (select models)	mph (kph)	12.4 (20) / 18.6 (30)	12.4 (20) / 24.9 (40)	12.4 (20) / 24.9 (40)	12.4 (20) / 24.9 (40)
Fuel tank capacity	gal (l)	15.8 (60)	22.5 (85)	22.5 (85)	31.7 (120)
Hydraulic oil tank capacity	gal (l)	15.2 (58)	13.2 (50)	13.2 (50)	16.9 (64)
HYDRAULIC SYSTEM		UNIT			
Work hydraulics discharge volume (optional)	gal (l)/min	14.8 (56) / 23.8 (90)	18.5 (70) / 30.4 (115)	18.5 (70) / 30.4 (115)	22.2 (84) / 31.7 (120)
Work hydraulics working pressure	psi (bar)	3,408 (235)	3,481 (240)	3,481 (240)	3,481 (240)
DRIVE		UNIT			
Drive type / drive system	-	Hydrostatic with universal joint shaft	Hydrostatic with universal joint shaft	Hydrostatic with universal joint shaft	Hydrostatic with universal joint shaft

* Weight will vary depending on configuration

** Bucket capacity based on density of 2,444 lbs / yd³, all others based on density of 2,750 / yd³

*** Boom extended



WL32	WL34	WL38	WL52	WL60	WL60T
ARTICULATED WHEEL LOADERS					
Perkins	Perkins	Perkins / Deutz	Deutz	Perkins	Perkins
47.9 (35.7) 60 (44.7)	47.9 (35.7)	60 (44.7) / 74.3 (55.4)	74.3 (55.4)	102 (76)	102 (76)
2,600	2,600	2,600	2,300	2,500	2,500
135 (2.2)	135 (2.2)	135 (2.2)	177 (2.9)	207 (3.4)	207 (3.4)
7,496 (3,400)	7,584 (3,440)	9,259 (4,200)	11,244 (5,100)	13,007 (5,900)	13,448 (6,100)
9,082	8,768	8,767	7,711	7,898	11,373
0.59 (0.45)	0.78 (0.6)	0.78 (0.6)	1.0 (0.8)	1.3 (1.0)	1.3 (1.0)
5,002 (2,269) / 4,206 (1,908)	5,919 (2,685) / 4,941 (2,241)**	6,576 (2,983) / 5,666 (2,570)	7,083 (3,213) / 5,986 (2,715)	8,100 (3,674) / 7,372 (3,344)	7,434 (3,372) / 7,020 (3,184) 4,211 (1,910) / 4,239 (1,923)***
4,184 (1,898) / 3,538 (1,605)	4,969 (2,254) / 4,145 (1,880)	5,498 (2,494) / 4,791 (2,173)	5,983 (2,714) / 5,079 (2,304)	6,682 (3,031) / 6,153 (2,791)	6,250 (2,835) / 5,900 (2,676) 3,499 (1,587) / 3,525 (1,599)***
-	-	-	-	-	-
3,347 (1,518) / 2,831 (1,284) 2,511 (1,139) / 2,123 (963)	3,975 (1,803) / 3,316 (1,504) 2,981 (1,352) / 2,487 (1,128)	4,398 (1,995) / 3,832 (1,738) 3,298 (1,496) / 2,875 (1,304)	4,786 (2,171) / 4,063 (1,843) 3,589 (1,628) / 3,047 (1,382)	5,346 (2,425) / 4,923 (2,233) 4,010 (1,819) / 3,693 (1,675)	5,000 (2,268) / 4,718 (2,140) 3,750 (1,701) / 3,538 (1,605) 2,800 (1,270) / 2,820 (1,279)** 2,099 (952) / 2,114 (959)**
-	-	-	-	-	-
12.4 (20)	12.4 (20)	12.4 (20) / 18.6 (30)	12.4 (20) / 18.6 (30)	12.4 (20) / 18.6 (30)	12.4 (20) / 18.6 (30)
17.2 (65)	14.5 (55)	17.2 (65)	21.7 (82)	27.7 (105)	27.7 (105)
9.2 (35)	17.2 (65)	13.2 (50)	17.4 (66)	25.1 (95)	25.1 (95)
14.8 (56) 26.4 (100)	13.1 (49.4)	14.8 (30.6) 30.6 (100)	19.4 (73.6) 30.4 (115)	26.4 (100) 39.6 (150)	26.4 (100)
3,046 (210)	3,046 (210)	3,046 (210)	3,336 (230)	3,046 (210)	3,408 (235)
Hydrostatic with universal joint shaft	Hydrostatic with universal joint shaft	Hydrostatic with universal joint shaft	Hydrostatic with universal joint shaft	Hydrostatic with universal joint shaft	Hydrostatic with universal joint shaft



WL32



WL34



WL38



WL52



WL60



WL60T

Dimensions

		5055	8085	8085T	8115L	WL32	WL34	
DIMENSIONS		ALL-WHEEL STEER WHEEL LOADERS						
	UNIT							
Standard tires (option)		12 x 18 A-317 (340/80 R18)	12.5-20 MPT-04	12.5-20 MPT-04	12.5-20 10PR	31x15.5-15 EM ET-37	15.5/55-18 EM ETO	
Standard bucket								
A	Overall length	in (mm)	194.4 (4,950)	207.9 (5,280)	231.9 (5,890)	228.3 (5,800)	187.2 (4,755)	194.2 (4,932)
B	Overall length (w/o bucket)	in (mm)	-	-	-	-	158.3 (4,022)	162.8 (4,135)
C	Overall width	in (mm)	62.6 (1,590)	70.1 (1,780)	70.1 (1,780)	77.6 (1,970)	55.7 (1,414)	63.0 (1,600)
D	Overall height	in (mm)	93.7 (2,380)	97.6 (2,480)	102.0 (2,590)	105.5 (2,680)	92.6 (2,351)	93.8 (2,383)
E	Max. height of the bucket pivot point	in (mm)	119.7 (3,040)	129.5 (3,290)	184.6 (4,690)	143.3 (3,640)	126.3 (3,208)	128.5 (3,263)
F	Overhead loading height	in (mm)	113.8 (2,890)	123.6 (3,140)	178.0 (4,520)	135.0 (3,430)	113.8 (2,890)	114.2 (2,901)
G	Dumping height	in (mm)	91.3 (2,320)	100.8 (2,560)	157.8 (4,010)	116.9 (2,970)	90.6 (2,300)	93.9 (2,384)
H	Reach	in (mm)	11.8 (300)	25.0 (635)	42.5 (1,080)	19.3 (490)	10.1 (259)	13.5 (344)
I	Ground clearance	in (mm)	10.6 (270)	13.0 (330)	13.0 (330)	15.4 (390)	10.8 (275)	12.6 (321)
J	Maximum outside radius	in (mm)	106.3 (2,700)	111.8 (2,840)	111.8 (2,840)	118.1 (3,000)	124.8 (3,171)	128.8 (3,271)
K	Maximum inside radius	in (mm)	-	-	-	-	68.1 (1,731)	68.2 (1,733)
L	Rollback angle at max. lift height	Degrees	40°	50°	45°	50°	56°	44°

WHEEL LOADER

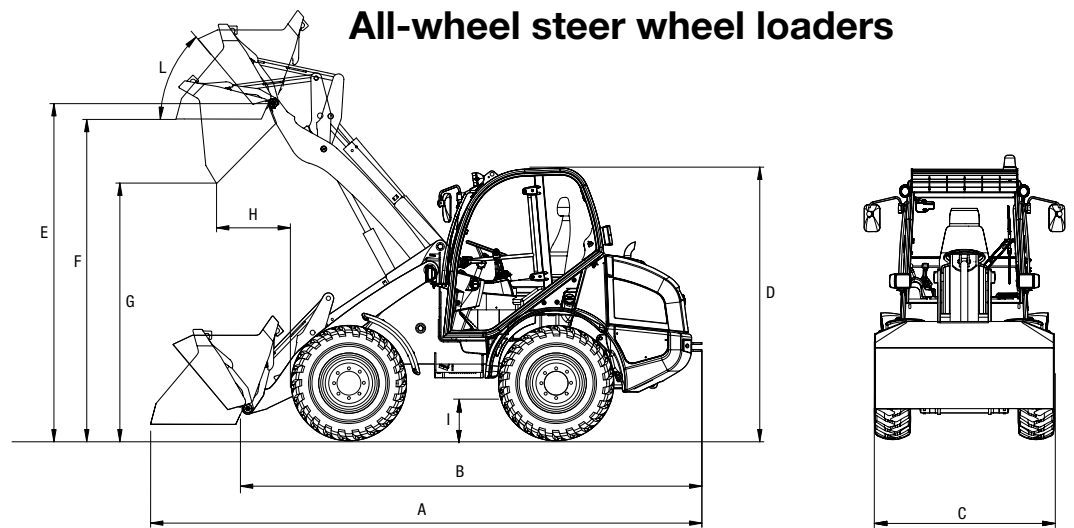

* Depending on the driver's cabin (fixed operator's canopy, fold-down operator's canopy, cabin)

WL38**WL52****WL60****WL60T****ARTICULATED WHEEL LOADERS**

15.5/55-18 EM ET 0	405/70R18	405/70R18	600/40-22.5 AS ET-50
202.3 (5,138)	216.1 (5,489)	232.2 (5,898)	251.8 (6,396)
171.0 (4,344)	183.0 (4,649)	188.2 (4,780)	204.7 (5,200)
61.8 (1,570)	73.8 (1,874)	72.0 (1,829)	71.9 (1,827)
93.3 (2,371) 100.3 (2548)	105.2 (2,672)	106.0 (2,693)	105.5 (2,679)
128.0 (3,251)	132.2 (3,358)	145.1 (3,686)	199.8 (5,076)
113.9 (2,892)	119.3 (3,029)	132.9 (3,375)	189.9 (4,823)
93.7 (2,379)	93.3 (2,521)	111.9 (2,841)	161.6 (4,105)
6.0 (155)	2.0 (625)	N/A	N/A
12.3 (312)	14.3 (364)	14.8 (375)	15.5 (393)
130.6 (3,317)	136.3 (3,461)	145.1 (3,686)	154.6 (3,928)
64.6 (1,640)	60.6 (1,538)	65.6 (1,666)	81.4 (2,068)
43°	44°	33°	45°

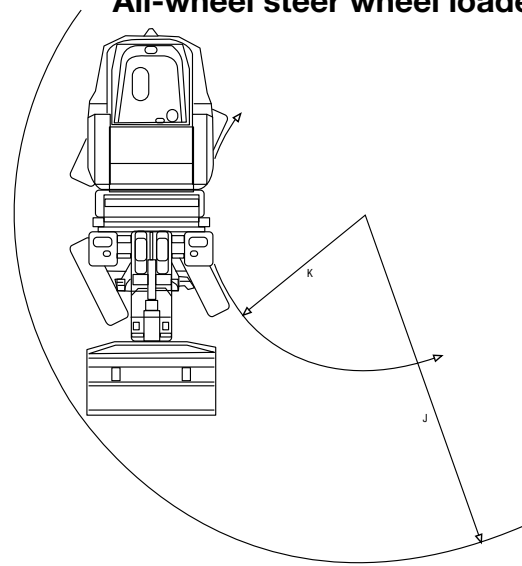
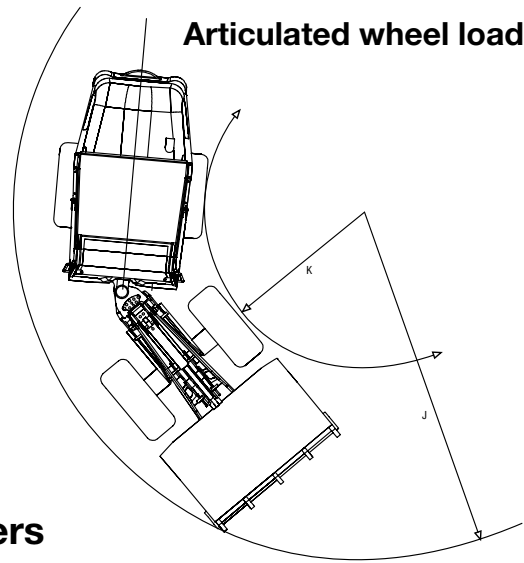
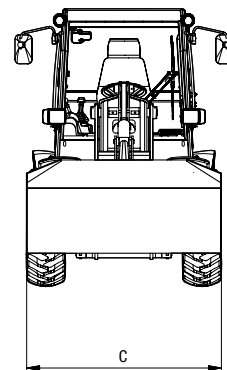
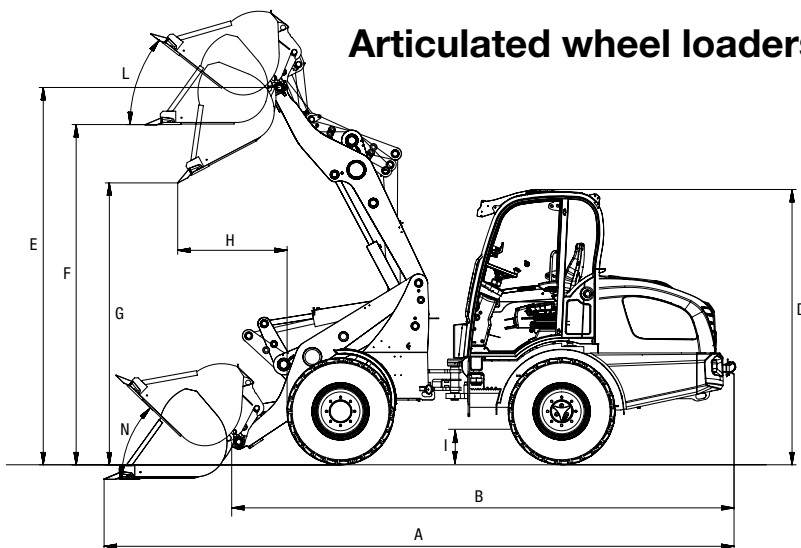
All-wheel steer wheel loaders**Articulated wheel loaders****Articulated wheel loaders**

Added value.

Warranty • Finance • Parts Availability



**WACKER
NEUSON**
all it takes!

Products are only as good as the service, technical support and training behind them. Wacker Neuson and our network of dealers provide everything you need to keep running at peak performance.



**2-YEAR
WARRANTY**

Warranty: Wacker Neuson's line of compact equipment features a factory standard 24-month/2,000 hour machine warranty. Ask your dealer about our extended service protection plan. Valid in USA and Canada.



**GENUINE
PARTS**

Parts and Service: A breakdown can cost you time and money. That's why all Wacker Neuson parts are available via our U.S. distribution center and are typically shipped within 24 hours of your order. You can count on getting the parts, service, maintenance and support you need, when you need them.



ACADEMY

Technical Training and Support: Wacker Neuson Technical Academy meets the training needs of contractors, mechanics and dealer sales people for years. Training classes are held at our production facility in Menomonee Falls, Wisconsin, just minutes from Milwaukee. Or, if you have a specific training need, we can bring the experts to your location. From in-depth industry-focused operation tips and process training to maintenance, our trained professionals can create a tailor-made program for you.



FINANCE

Flexible Financing:

- Low down payments
- Competitive rates
- Cash back options
- Seasonal payment options

Wacker Neuson is a global equipment manufacturer for the construction, agriculture, oil and gas, landscape, utilities and municipal industries. Our comprehensive portfolio stands firmly on outstanding reliability, innovative technology, personal service and close customer contact. In the United States and Canada, Wacker Neuson's full line of products are sold and rented by a network of over 4,000 dealers and supported by an industry leading team of factory trained sales, application and service personnel.



Blanchard Machinery Inc.
1890 N.E. 150 Street
North Miami Fla. 33181
bmisalz@aol.com
www.blanchardmachinery.net